

I-20 User Manual

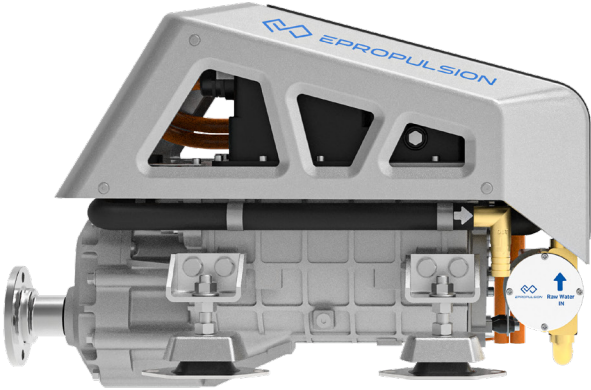

Acknowledgement

Thanks for choosing ePropulsion products, your trust and support in our company are sincerely appreciated. We are dedicated to providing high-performance electric outboards, electric inboards, sup/kayak motors, reliable lithium batteries and accessories.

Welcome to visit www.epropulsion.com and contact us if you have any concerns.

Using This Manual

Before use of the product, please read this user manual thoroughly to understand the correct and safe operations. By using this product, you hereby agree that you have fully read and understood all contents of this manual. ePropulsion accepts no liability for any damage or injury caused by operations that contradict this manual.

Due to ongoing optimization of our products, ePropulsion reserves the rights of constantly adjusting the contents described in the manual. ePropulsion also reserves the intellectual property rights and industrial property rights including copyrights, patents, logos and designs, etc.

This manual is subject to update without prior notice, please visit our website www.ePropulsion.com for the latest version. If you find any discrepancy between your products and this manual, or should you have any doubts concerning the product or the manual, please visit www.ePropulsion.com.

ePropulsion reserves the rights of final interpretation of this manual.

This manual is multilingual, in case of any discrepancy in the interpretation of different language versions, the English version shall prevail.

Symbols

ePropulsion considers safety of great importance and recommends that anyone that comes into close contact with its products, such as those who install, operate, maintain or service ePropulsion products, exercise care, common sense and comply with the safety information in this manual and on the machine's safety decals.

The following are the relevant information marks in the user manual or the product labels:

Hazardous or warning signs indicate a potentially hazardous or hazardous situation which, if not avoided, will result in death or serious injury. Special attention and attention should be paid to the safety of you or the products involved.



Important warning:

Tips or important informations help quickly grasp the use of the inboard motor and improve efficiency.

Please read and follow the instructions following the safety warning signs.



Caution:

When installing, operating, maintaining or serving ePropulsion products, there are many safety risks in the process. You need to be alert, perform relevant operations reasonably, and pay attention to safety. when installing, operating, maintaining or serving ePropulsion products, there are many safety risks in the process. You need to be alert, perform relevant operations reasonably, and pay attention to safety.



Entanglement hazard:

Rotating parts can cause severe injury or death. Never wear jewelry, unbuttoned cuffs, ties or loose-fitting clothing and always tie long hair back when working near moving/rotating parts such as the flywheel or PTO shaft. Keep hands, feet and tools away from all moving parts.



Electric shock hazard:

The areas or equipment may be at risk of electric shock. The equipment uses 102.4V DC power. When operating electricity-related electrical connectors, switches, cables and other electricity-related items, power off operation to prevent electric shock.



Burn hazard:

Some of the machine surfaces become very hot during operation and shortly after shutdown. Keep hands and other body parts away from hot machine surfaces.



Do not approach when the machine is running:

The machine and equipment are in operation. Do not approach or touch the machine to avoid dangers.



Do not plug or unplug when the machine is running:

Do not plug or unplug electrical equipment when the machine is running to avoid the risk of electric shock.

Product Identification

Below picture indicates the serial numbers of the I-20 inboard motor. Please note the position of the serial numbers and record them for access to warranty service and other after-sale services.

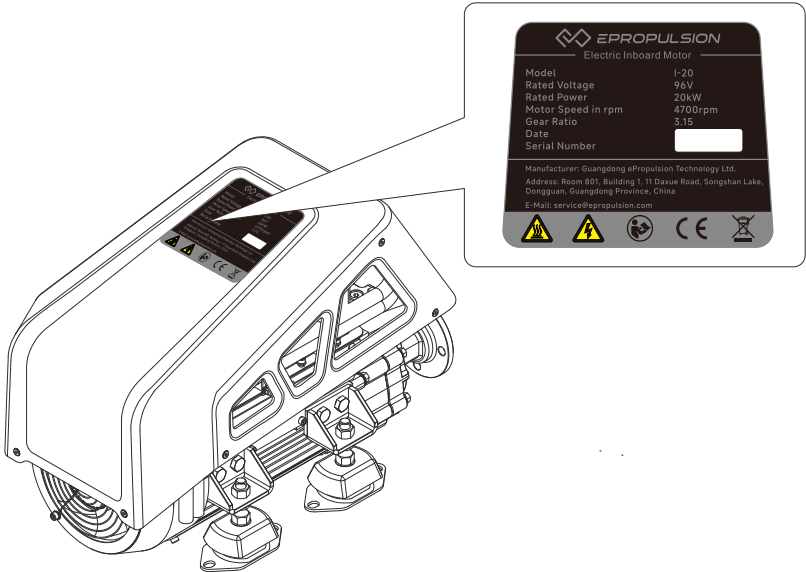

Product Label

Table of Contents

- Acknowledgement..... 1
- Using This Manual 1
- Symbols 1
- Product Identification 3
- 1 Product Overview 7
 - 1.1 In the Package 7
 - 1.2 Parts and Diagram..... 11
 - 1.3 Specifications 11
 - 1.4 Instructions before Use 12
- 2 Unpacking steps and notices 14
 - 2.1 Safety Notice..... 14
 - 2.2 Tools and equipment required for unpacking 14
 - 2.3 Check the packaging 14
 - 2.4 Check the packaging 14
 - 2.5 Remove the inner packaging and inspect the product 15
 - 2.6 Dispose of discarded packaging materials..... 16
- 3 Install the I-10 motor 17
 - 3.1 Install the motor 17
 - 3.1.1 Before installation 17
 - 3.1.2 Center the output shaft 19
 - 3.1.3 Lock the output shaft and fix the suspension 21
 - 3.2 Connect seawater inlet and outlet pipes 23
- 4 Connect the system before operating the machine 24
 - 4.1 System connection diagram 24
 - 4.1.1 System connection diagram of the single-motor 24
 - 4.1.2 System connection diagram of the dual-motor..... 25
 - 4.1.3 Notes..... 27
 - 4.2 Make a cable (crimped cable lug) 27
 - 4.3 Cable connection..... 29
 - 4.3.1 Cable connection at the bus bar 29
 - 4.3.1.1 Required accessories and tools..... 29

4.3.1.2 Installation.....	29
4.3.2 Connect the DC-DC module.....	32
4.3.2.1 Required accessories and tools.....	32
4.3.2.2 Installation.....	32
4.3.3 Connect the G102-100 Battery.....	33
4.3.3.1 Required accessories and tools.....	33
4.3.3.2 Installation.....	33
4.3.4 Connect the DC-DC module to the 12V battery.....	33
4.3.4.1 Required accessories and tools.....	33
4.3.4.2 Installation.....	33
4.3.5 Connect the power cable of the motor of the ship.....	34
4.3.5.1 Required accessories and tools.....	34
4.3.5.2 Installation.....	34
4.3.6 Connect interactive devices and accessories.....	36
4.3.6.1 Required accessories and tools.....	36
4.3.6.2 Installation.....	36
4.3.7 Connection of communication terminator.....	40
4.3.8 Status after connection.....	41
5 Operation.....	42
5.1 Smart Throttle Button Description.....	44
5.2 Start the Machine.....	44
5.2.1 Boot Operation.....	44
5.2.2 System problem feedback method after startup.....	44
5.3 Perform initial configuration.....	44
5.4 Home Page.....	47
5.5 Powertrain diagram.....	49
5.5.1 Control console.....	49
5.5.2 Power Battery.....	51
5.5.3 Propeller.....	51
5.6 Setting.....	51
5.6.1 Propulsion Setting.....	52
5.6.1.1 Propulsion switch.....	52
5.6.2 Control console Settings.....	53
5.6.2.1 Smart throttle settings.....	53



5.6.2.2 Display settings	55
5.6.3 General setting	56
5.6.3.1 System firmware information	56
5.6.3.2 Maintenance - All maintenance timing tips.....	57
5.6.3.3 ePropulsion Connectivity Service	58
5.7 Connectivity	58
5.7.1 Mobile application	58
5.7.2 How to connect.....	60
5.7.3 OTA update.....	63
5.8 Motor operation.....	64
5.8.1 Start	64
5.8.2 Adjust power	64
5.8.3 Stop.....	65
5.8.4 Notices.....	65
5.9 Troubleshooting	66
5.9.1 Mechanical faults	66
5.9.2 System faults.....	67
6 Maintenance.....	71
6.1 Repair and maintenance:.....	71
6.2 Part of the repair and maintenance guide	72
6.2.1 Repair flexible impeller pump	72
6.2.2 Regular cleaning of heat exchanger	73
6.3 List of fasteners	75
7 Warranty	76
7.1 Out of Warranty	77
7.2 Limited Warranty Claim Procedures.....	78



1 Product Overview

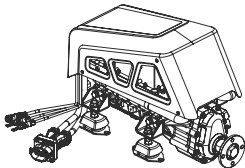
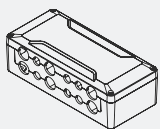
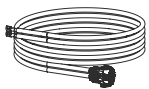
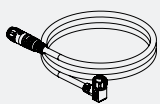

The I-Series 10kW inboard motor is an electric inboard motor with input power of 10kW, which is controlled by a smart throttle and smart display. The electric inboard motor is environmentally friendly, clean and efficient. The I-10 inboard motor is perfect for small and medium-sized recreational vessels, such as all types of yachts, leisure boats and sailboats, which range from 5 to 20m.

1.1 In the Package

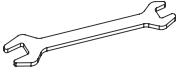

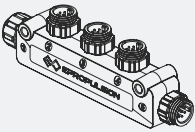
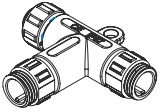
When you receive the inboard motor, unpack its package and check if all the items below are included in the package. If there is any loss or transport damage, please contact your dealer immediately.

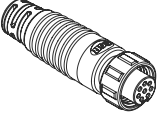
Items	Qty.	Figure	Function
I-20 main part	1		Provide the ship's propulsion, driving the ship.
Bus bar	1		Transfer the electrical energy of the power supply from the main circuit of the power supply system to different components or modules in the circuit.
High voltage bus cable 5m (Cut into Battery to bus bar power cable and Motor to bus bar power cable)	1		Transfer DC power from the battery to the power input of the motor to provide the power needed for normal operation of the motor.
CAN Communication cable 1m	1		Connect the motor and other devices such as the smart throttle, smart display and battery.
CAN comm extension cable 10m	1		Extend the communication distance of the CAN communication cable

Items	Qty.	Figure	Function
Open-end wrench	2		Mount the suspension fasteners, adjust the height and lock the fastener of the output flange shaft.
Hex wrench	2		The 3mm wrench is used for fixing and locking the bus bar The 5mm wrench is used for fixing and locking the DC-DC
Fasteners	/	<ol style="list-style-type: none"> 4 cross groove outer hexagonal flange tapping screws; 4 M6x16 hex socket head bolts; 4 M10x45 outer hex bolts; 8 M10 hex nuts; 8 M10x18 outer hex bolts. 	<ol style="list-style-type: none"> Bus bar fastening screw. Bus bar fastening screw (reserved). Output flange locking bolt. Output flange locking nut. Suspension fastener.
Red and black heat shrink tubes	2	0.5 m	Protect the main power cable after stripping it
Cable lug	6	SC50-8	Retrofit terminal for rear end of main power cable
5-way T-connector	1		Connect the motor and each device to the CAN communication network (controller LAN)
3-way T-connector	1		Connect the motor and each device to the CAN communication network (controller LAN)

Items	Qty.	Figure	Function
Communication terminator	2		Improve the quality of communication
User manual Warranty card	1		Give information about the features, functions, performance, purpose and maintenance of the product.

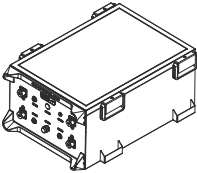
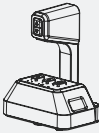
Other accessories not included in the package are also required to operate the outboard motor, such as smart throttle, smart display, battery, charger and communication cable, etc. Users can buy official accessories provided by ePropulsion from ePropulsion authorized dealers. The accessories list is shown below:

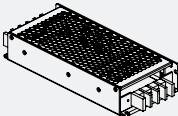
Items	Qty.	Figure	Function
G102 battery	1		Provides reliable power for the entire system
Smart throttle	1		Start, stop the motor and control the power output
Smart display	1		Display system information such as power, speed, battery level and set system functions
DC-DC	1		Used as 102.4V to 12V DC function, to provide a 12V stable power supply to the system

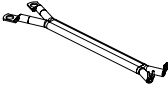
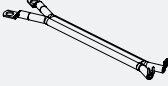
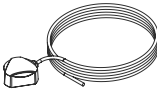
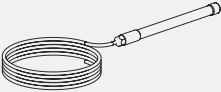
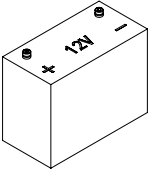
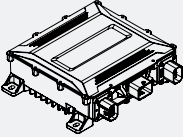
Items	Qty.	Figure	Function
Bus bar to DC-DC power cable 5m	1		Connect the bus bar to the input interface of the DC-DC module to provide input power to the DC-DC
DC-DC to 12V battery power cable 1.5m	1		Connect the output interface of the DC-DC module to the 12V battery, so that the DC-DC module can charge the 12V battery
GPS module	1		Obtaining a ship's Global Positioning System (GPS) signal can provide the ship's position and speed information, helping ship managers with ship management and adjusting course plans.
4G antenna	1		The 4G antenna is a kind of communication equipment. The machine realizes remote network connection through the 4G antenna to realize remote control and monitoring. At the same time, it can support high-speed data transmission, which is convenient for the crew to carry out online data sharing and backup operations.
12V battery	1		Provide electrical energy for the system's 12V power requirements equipment
3.3kW charger	1		Charge the G102 battery

1.2 Parts and Diagram

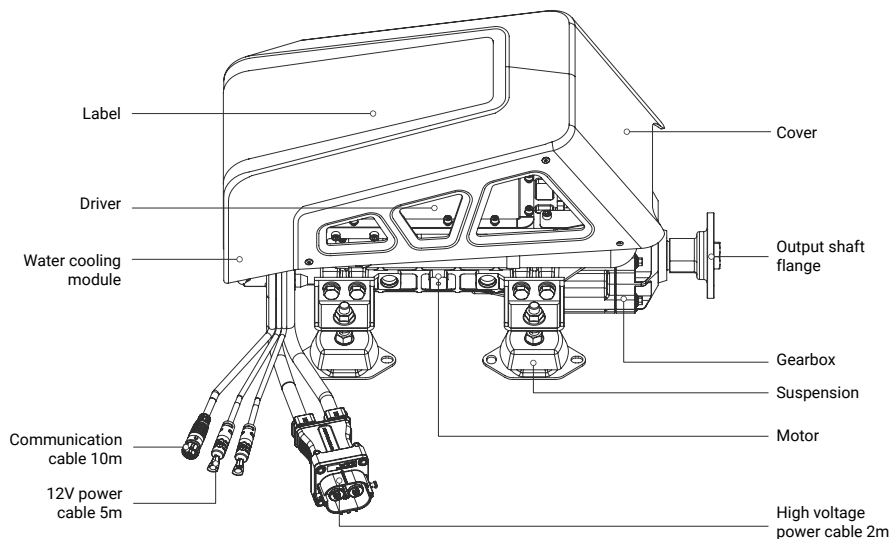

Figure 1-1

1.3 Specifications

Input power	20kW
Recommended battery	ePropulsion Lithium Iron Phosphate Battery
Input voltage range	86~115V (high voltage); 9V~16V (low voltage)
Rated output torque	140N.m
Weight	49.5kg
Dimensions (L*W*H)	580*330*380mm
Cooling method	Water cooling (air cooling)
Rated power rotational speed range	1200rpm~1700rpm

Operation/storage temperature	-5°C ~ 55°C /-25°C ~70°C
Operation and interaction mode	Remote control, display panel
ePropulsion Connectivity Service	Supported
Partial driver assistance	Support route planning by dual motors
Vibration-damping components	Four-point elastic rubber mount



It is suggested that the 12V battery is required to possess over 18A of continuous discharge current.



When the voltage is below 96V, it will be an undervoltage alarm.



1.4 Instructions before Use

1. Only adults who have fully read and understood this manual are allowed to operate this product. Read the full user manual carefully before operation, ePropulsion accepts no liability for any damage or malfunction caused by operations violating this manual.
2. Only boat owners who are familiar with their boats are allowed to use this inboard motor. For a newly bought boat, the boat owner should learn all aspects of the boat including how the boat behaves in different conditions and practicing controlling the boat before mounting and operating this inboard motor.
3. Before operation, familiarize yourself with all the functions and operations of this product. If there is more than one person onboard, make sure you are not the only one onboard who knows how to operate this inboard motor to help in case of an unforeseen emergency.
4. Follow boat builder's instructions to mount this product to your boat. It is suggested to have certified boat builders or professional installers to install this inboard motor to your boat. Never try to install the inboard motor on your own if you never have experience of mounting the inboard to your boat before.
5. Check the weather before operation. Avoid sailing in dangerous weather conditions.
6. If the inboard motor system is the only power source of your boat, make sure batteries on board have enough power for your round trip. We recommend you to calculate distance and battery consumption.



7. Check before each trip if there is enough safety equipment including but not limited to enough life jackets, personal flotation devices, fire extinguishers, bells and whistles, communication equipment, and paddles, etc. Check available local boating safety requirements before operating.
8. If the inboard motor strikes other objects in the water, please stop running immediately. Return to the nearest harbor and find your dealer for assistance.
9. Stop the inboard motor immediately if someone falls into water.
10. Only run the inboard motor while the propeller is underwater.
11. Every occupant of the vessel shall be fitted with a qualified life jacket (PFD). Wear a life jacket when sailing. When operating, tie the cable of the safety switch to a firm position such as hand, foot or clothing. If accidentally left the steering position, the cable will drag the switch and stop the in-boat machine.
12. Before each voyage, please be sure to check the state and battery power of the engine on board.
13. Please report the sailing plan to relevant personnel (dock and family members, etc.) before leaving the port
14. When moving inside the ship, watch carefully for swimmers and stay away from them. Stay away from swimming areas.
15. Do not cover the GPS and 4G external antenna to avoid signal attenuation.
16. The distance and speed values shown are measured by the Global Positioning System (GPS) and may be subject to minor errors due to weak GPS signal or changes in external environments such as ocean currents, wind, etc.
17. Familiarize yourself with all operations of the engine on board, including starting, stopping, accelerating, decelerating, reversing, etc.
18. If the engine on board fails, the smart display will display an error message. Refer to the detailed instructions and corresponding solutions.
19. For safety reasons, the system will automatically shut down during operation if the motor or driver temperature is too high or the battery voltage is too low.

2 Unpacking steps and notices



2.1 Safety Notice

-  Use appropriate safety equipment, wear gloves, protection shoes and other safety props;
-  Ensure that all safety and measures are understood before operation;
-  Due to the large weight of the product, ensure that at least two people operate;

2.2 Tools and equipment required for unpacking



-  Prepare unpacking tools, such as rubber hammer, screwdriver, etc.
-  Handling tools: wheelbarrow/forklift.

2.3 Check the packaging

-  Check the wooden case for obvious damage or transportation damage and record;
-  Verify that the label on the package is consistent with the product purchased;

2.4 Check the packaging

- Carefully insert the forklift into the wooden bracket, ensure the wooden case is stable, and move the wooden case to the appropriate unpacking area;
- Straighten the iron sheet around the upper wooden cover plate with a tool and remove the cover plate;
- Remove the manual and maintenance card;
- Take out the communication cable, 12V power cable, heat shrink tubes, high voltage bus cable, accessory pack, bus bar in turn;
- Remove the iron sheet of the package and remove the wooden frame;
- Organize the machine communication cables and power cables;
- Disassemble the accessory pack and remove the motor from the board with an open wrench (17-19).

-  Pay attention to avoid damage to the product during unpacking. Check all accessories, and confirm that accessories are all complete.
-  The package list refers to **1.1 In the Package**

The composition of the package is shown below:

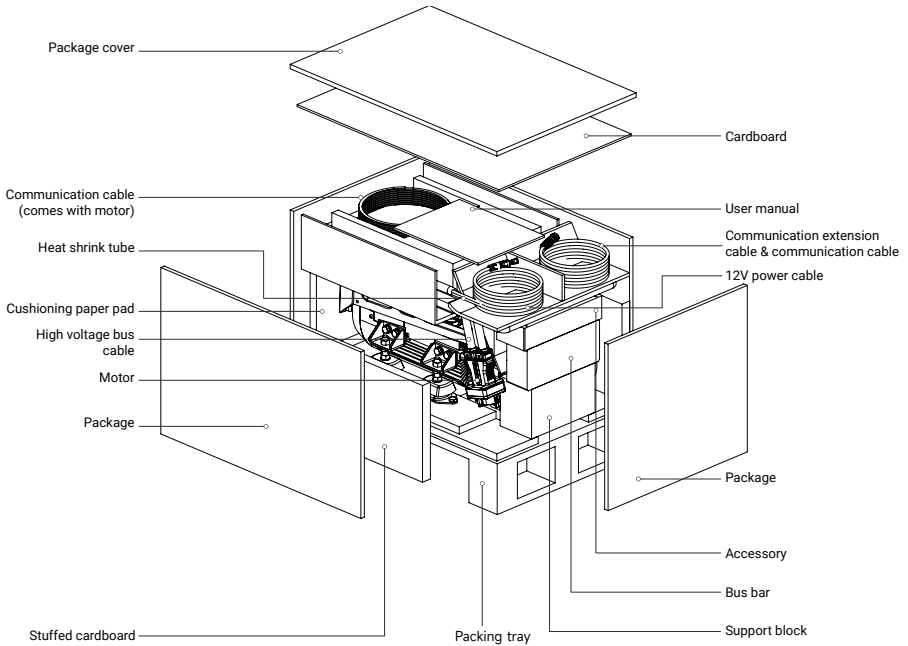

Figure 2-1



2.5 Remove the inner packaging and inspect the product

1. Remove the protective bubble bag of the motor and check whether there is any abnormal appearance, such as deformation, scratching, etc.;
2. Unpack the motor cables (high-voltage power cables, 12V power cables, communication cable) to check whether the cables are complete or damaged;
3. Open the bus bar package, and check whether the components are damaged, abnormal in appearance, or missing;
4. Take out CAN communication extension cable, CAN communication cable, main power cable, check whether the appearance is abnormal;
5. Sort out the motor, accessories, packaging and other related materials.



Check the product for broken or missing parts, if there is a problem, please contact ePropulsion after-sales service for help.

2.6 Dispose of discarded packaging materials

1. Classify and recycle packaging materials, such as wood, paper, etc.
2. Follow local environmental regulations to dispose of waste materials.
 -  Make sure to read the user manual that come with the product carefully.
 -  Please follow the local material handling requirements to recycle the package, reasonable disposal, to protect the environment.

3 Install the I-20 motor

3.1 Install the motor

The quality of installation plays a decisive role in the reliability of the whole system. Among them, the output shaft in the center and the suspension is the most critical. If you want the system to be stable and reliable, please refer to the following requirements for installation to ensure that the equipment works in a good state.

3.1.1 Before installation

1. Check the materials:

- ① Motor: Check the I-20 machine structure to ensure that there is no loosening or abnormality. Arrange the main power cables, 12V power cable, and communication cable and fix them in appropriate positions for easy handling.
- ② Tools: Open-end wrench, wheelbarrow, gloves.
- ③ Accessories: 8 M10x45 hex bolts, 4 M10 hex nuts, 8 M10x18 hex bolts.

2. Confirm the drawing file of the motor:

I-20 dimensions are shown in the following. Before installation, please carefully check the size to ensure sufficient installation space, accurate installation position, convenient adjustment, to meet the installation requirements.

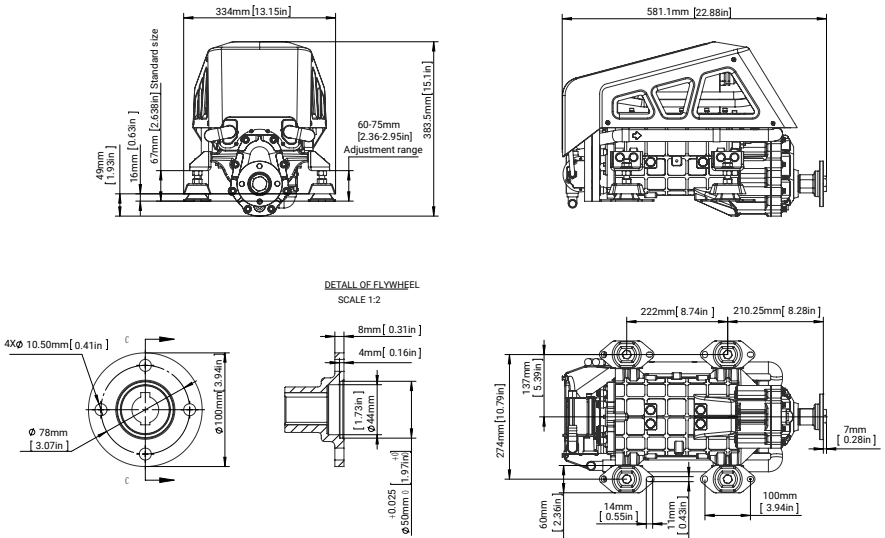

Figure 3-1



Suggestions for the mounting platform:

First, design the proper mounting platform according to the size model of the motor, the space inside the ship and the position of the stern shaft. The size of the fastening hole of the mounting platform is M10, and the size distribution is determined according to the position of the fixing hole of the suspension support foot. The motor platform is firmly fastened to the hull, and can bear a large thrust (greater than 7000N).



Pre-installation work:

- ① Confirm the motor model: motor size, weight, voltage, power and the current ship match;
- ② Design layout: read the user manual, need to consider the layout and design of the whole system. Machine and related system components must be installed in the appropriate position on the ship to ensure safe and efficient operation.
- ③ Simulate the installation process: according to the installation process of the user manual, simulate the relevant process to ensure that the installation is feasible and the installation process is low risk.
- ④ Clean the environment inside the ship: clean up irrelevant objects according to the simulation process, keep dry and clean. Ensure that the installation process is smooth and the commissioning process is normal.



Suggestions for lifting:

Before hoisting, sort out the cables and fix them on the motor. Suspend two feet around the motor through the sling, complete the lashing of the rope, pass through the hook, adjust the position of the hook, and test hoisting. In the test hoisting, the machine is stable without tilting and shaking, then formal hoisting can begin.

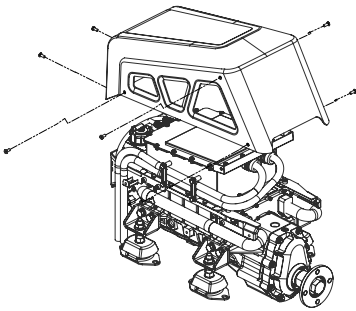

1. Remove the cover.

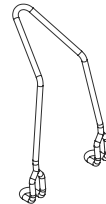

2. Wrap the rope and hoist the machine

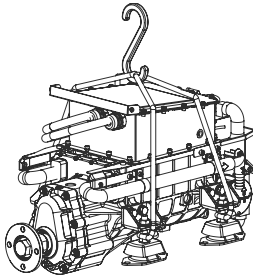

Lifting objects hazard: pay attention to safety when hoisting equipment or objects nearby to avoid being hurt or crushed by falling objects.



The cover shall be installed after the 4G antenna is installed.

3.1.2 Center the output shaft

1. Adjust the distance between the stern shaft and the motor mounting platform in advance according to the key dimensions of the figure, as the figure shown in the following.

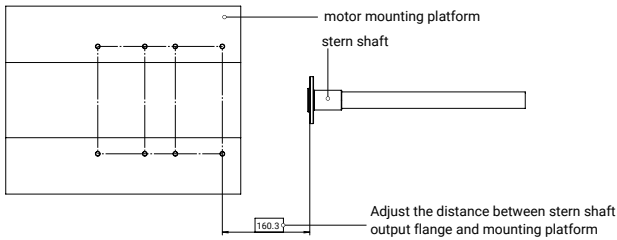

Figure 3-4

2. Hoist the motor to the mounting platform. The output shaft of the motor and the transmission center axis of the stern shaft are spatial crossing lines, which can not be aligned.

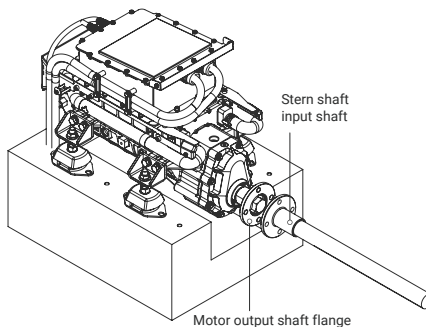

Figure 3-5

3. Move the motor so that the output shaft flange of the motor is close to the input shaft flange of the stern shaft, align the input shaft flange of the stern shaft, and compare the height difference between the output shaft and the input flange of the stern shaft. Adjust the suspension height, the ship machine shaft flange and the stern shaft input flange to adjust to the same height;

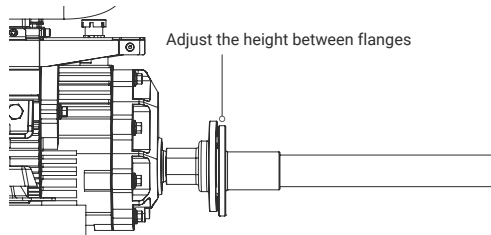

Figure 3-6

Adjust the height of the motor:

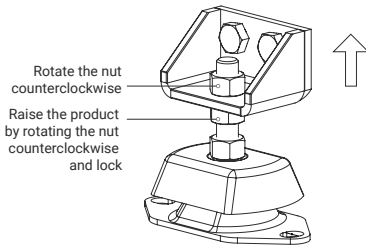

Figure 3-7 Product height adjustment

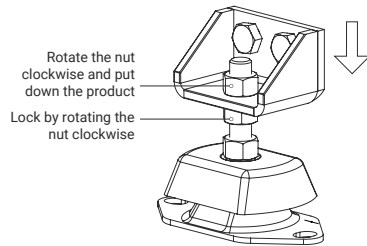

Figure 3-8 Product height adjustment

4. Confirm the height adjustment. Adjust the height to be consistent by observation and touch.

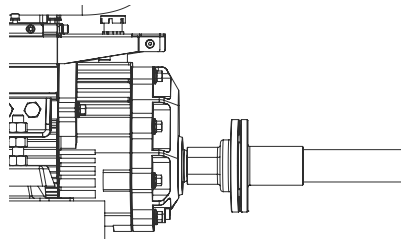

Figure 3-9 After the height adjustment

5. Flange surface fitting, flush the outlet flange with the stern shaft input flange end face, so that the positioning boss is embedded in the output shaft flange, so that the two flange faces fit, observe the size of the gap. (Note: pay attention to the mounting position of the suspension simultaneously)

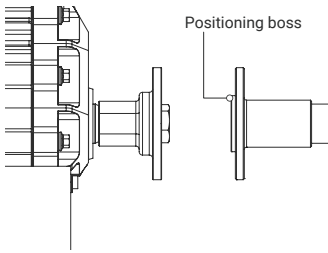

Figure 3-10

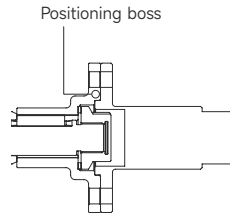

Figure 3-11

6. Fine tune, observe the size and distribution position of the gap, and fine tune the suspension to ensure the gap can not be seen.

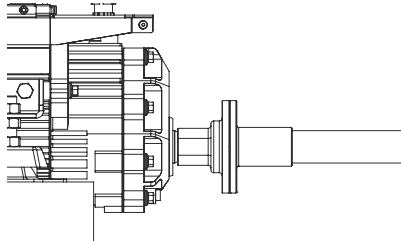

Figure 3-12

3.1.3 Lock the output shaft and fix the suspension

1. Lock the output shaft flange and stern shaft flange.



It is recommended to use elastic coupling, which can be better compatible with coaxial error, reduce assembly deviation force, and improve equipment reliability and service life

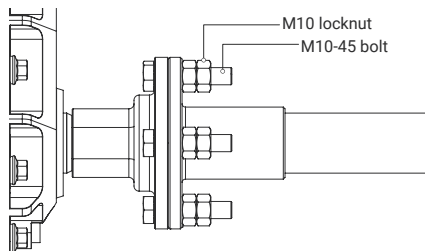

Figure 3-13

2. Fix the suspension, observe whether the suspension and the bench are flush, do appropriate fine tuning, make the bottom surface of the suspension stick to the upper surface of the installation platform, lock the fixing bolts of the suspension.

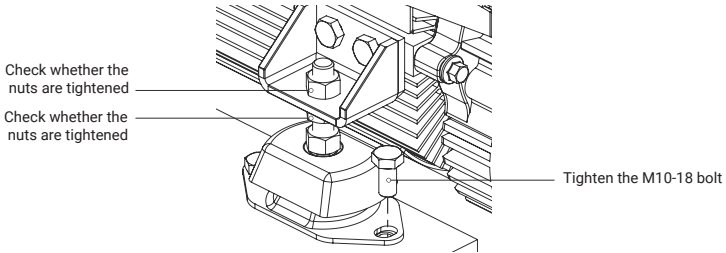

Figure 3-14

After the output shaft alignment is completed, the output shaft is locked and suspension is fixed, manually rotate the flange for one circle to check whether there is any obvious abnormality in the overall structure.



Caution: when installing, operating, maintaining or serving ePropulsion products, there are many safety risks in the process. You need to be alert, perform relevant operations reasonably, and pay attention to safety.

3.2 Connect seawater inlet and outlet pipes

The machine has a water pump. According to the logo in the above figure, the water pipes with an inner diameter of 19mm are selected to be connected to the water inlet and the water outlet respectively, and the water pipes are fixed on the pagoda joint with clamps.

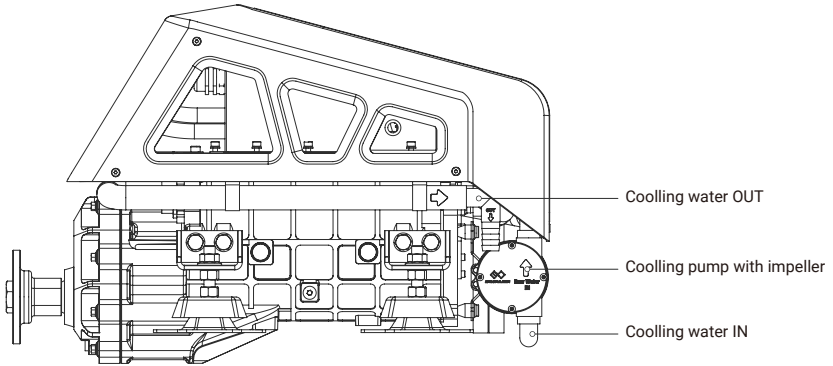

Note:

1. Water pipes and clamps are provided by the customer.
2. The suction head of the pump is limited. Please control the length of the inlet pipe within 5m to avoid the impeller not pump water if the pipeline is too long.
3. When replacing the water pump impeller, you only need to remove the left and right bolts of the front end of the water pump.
4. Sediment and aquatic plants in the water will greatly reduce the service life of the impeller. It is recommended that customers add filters to the water inlet of the boat to remove large foreign bodies such as aquatic plants, and set filters in the water inlet line to separate sediment and other small foreign bodies, and regularly clean the filter.

4 Connect the system before operating the machine

4.1 System connection diagram

4.1.1 System connection diagram of the single-motor

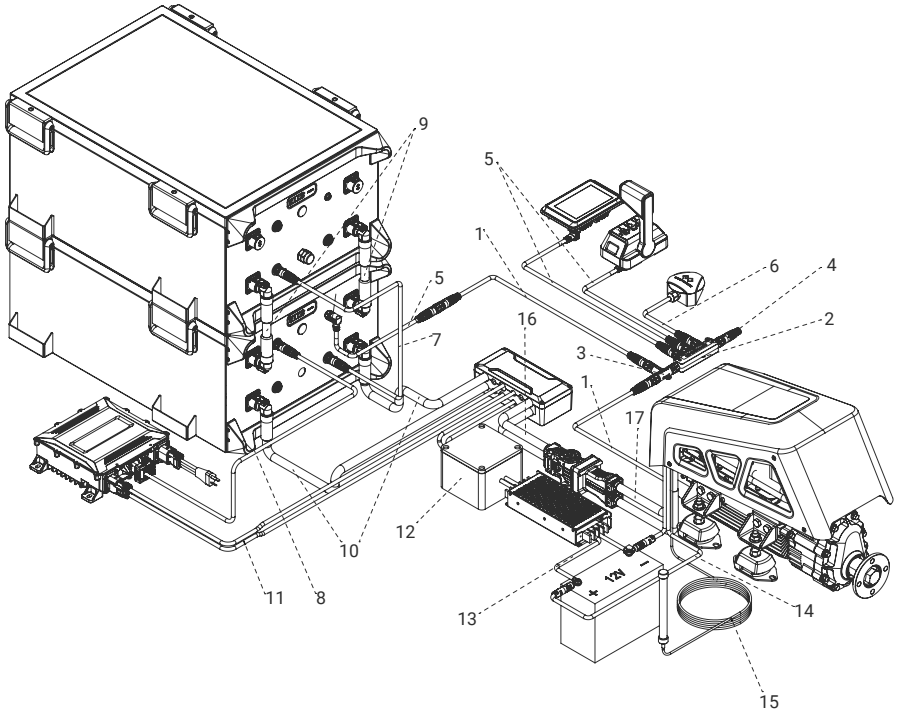

- 1. CAN Comm extension cable
- 2. 5-way T connector
- 3. 3-way T connector
- 4. Communication terminator
- 5. CAN Communication cable
- 6. GPS Communication cable (10m, comes with GPS)
- 7. Battery Communication Cable
- 8. Charger Communication Cable
- 9. Battery Bridging Cable
- 10. Battery to bus bar power cable
- 11. Charger output power cable
- 12. Bus bar to DC-DC power cable
- 13. DC-DC to 12V battery power cable
- 14. 12V power cable of motor (5m, comes with motor)
- 15. 4G antenna cable
- 16. Motor to bus bar power cable
- 17. Main power cable (2m, comes with motor)

4.1.2 System connection diagram of the dual-motor

1. For dual-motor with a 12V battery

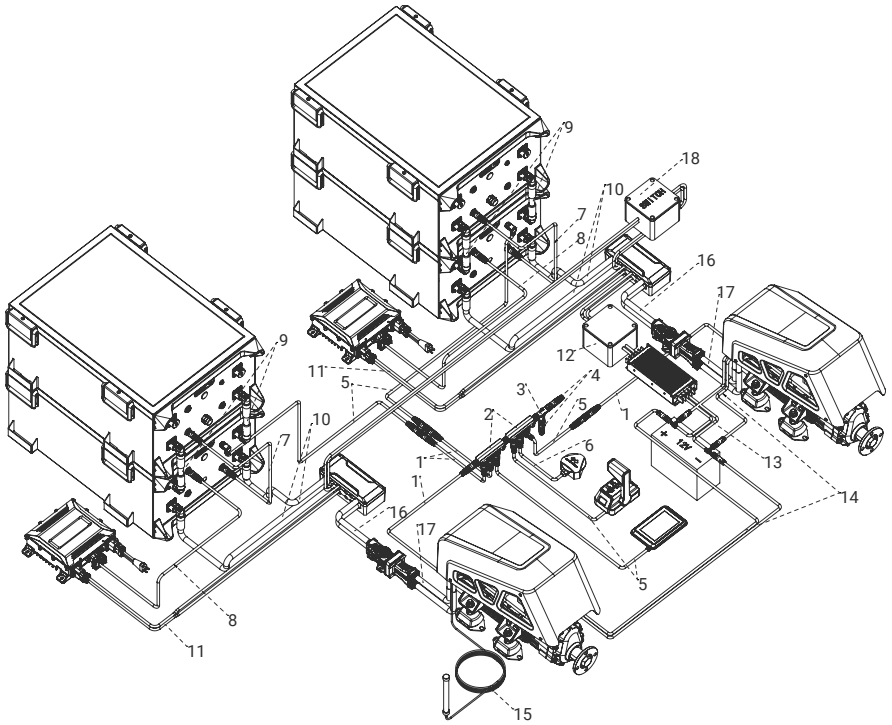

- | | |
|--|---|
| 1. CAN Comm extension cable | 10. Battery to bus bar power cable |
| 2. 5-way T connector | 11. Charger output power cable |
| 3. 3-way T connector | 12. Bus bar to DC-DC power cable |
| 4. Communication terminator | 13. DC-DC to 12V battery power cable |
| 5. CAN Communication cable | 14. 12V power cable of motor (5m, comes with motor) |
| 6. GPS Communication cable (10m, comes with GPS) | 15. 4G antenna cable |
| 7. Battery Communication Cable | 16. Motor to bus bar power cable |
| 8. Charger Communication Cable | 17. Main power cable (2m, comes with motor) |
| 9. Battery Bridging Cable | 18. Busbar connection switch assembly |

2. For dual-motor with two 12V batteries

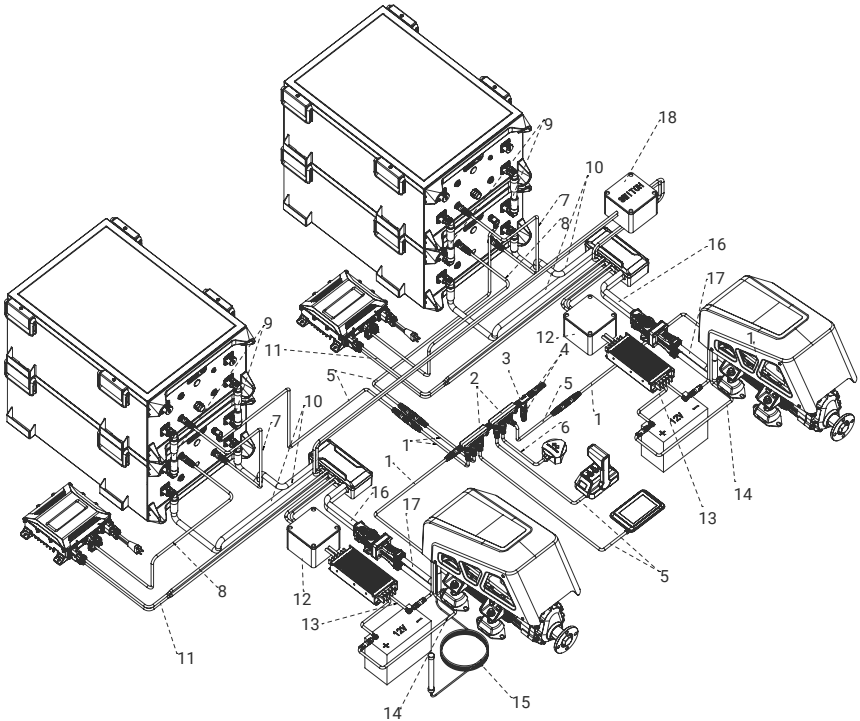

- | | |
|--|---|
| 1. CAN Comm extension cable | 10. Battery to bus bar power cable |
| 2. 5-way T connector | 11. Charger output power cable |
| 3. 3-way T connector | 12. Bus bar to DC-DC power cable |
| 4. Communication terminator | 13. DC-DC to 12V battery power cable |
| 5. CAN Communication cable | 14. 12V power cable of motor (5m, comes with motor) |
| 6. GPS Communication cable (10m, comes with GPS) | 15. 4G antenna cable |
| 7. Battery Communication Cable | 16. Motor to bus bar power cable |
| 8. Charger Communication Cable | 17. Main power cable (2m, comes with motor) |
| 9. Battery Bridging Cable | 18. Busbar connection switch assembly |



In a dual battery group & dual motor configuration, When a battery group fails, please turn off the failed battery group, switch on the busbar connecting switch, those two busbars will be connected, the single battery group can supply power to those double engines so as to ensure the normal operation of the ship, When a single battery supplies power to two engines, the system will enter limp mode, the power of the engines will be reduced to half of the rated power.

4.1.3 Notes

1. Do not cover the 4G antenna and GPS module to avoid wireless signal attenuation.
2. When using batteries, make sure the main switch is off before connecting.
3. Users can also connect multiple batteries in parallel to expand battery capacity.



For details about battery usage and notices, refer to the G102 battery user manual.

4.2 Make a cable (crimped cable lug)

When you receive the cable, "Motor to bus bar power cable" and "Battery to bus bar power cable" are integrated. You need to cut the integrated cable from an appropriate position according to the placement and distance of the battery, bus bar and inboard motor on board. And crimp the cable lug (a total of 4 cable lugs needs to be crimped) at the cutting place to make "Motor to bus bar power cable" and "Battery to bus bar power cable".

Tools needed to make the cable:

No.	Tools	Recommended model
1	Wire cutter	EC-50M
2	Wire stripper	SW-1018
3	Crimping plier	UAR EK-630

Crimping cable lugs:

- (1) Use a wire cutter to cut the cable from an appropriate position.

The cable after cutting is shown below:

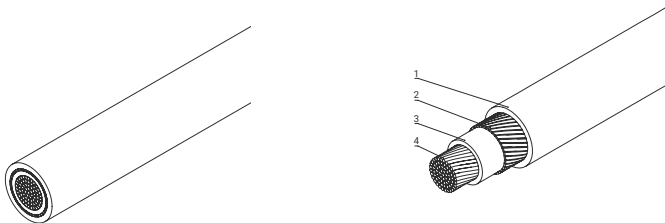

The section structure of the cable is shown in the figure above.

① Outer sheath; ② metal shielding layer; ③ inner sheath; ④ copper core conductor

(2) Use a wire stripper to strip the length of the "① outer sheath" by 20mm(+5,-0)mm.

The cable after peeling off the outer sheath is shown below:

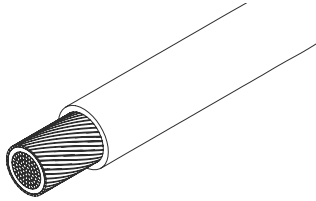

(3) Use a scissor to cut 10mm(+5,-0)mm of the exposed "② metal shield layer".

The cable after cutting off the "② metal shield" is shown below:

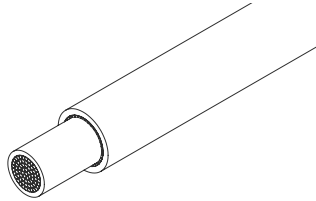

(4) Use a wire stripper to strip the length of the "③ inner sheath" of 10mm±2mm.

The cable after peeling off the "③ inner sheath" is shown below:

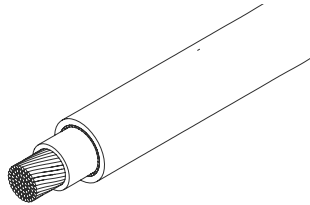

(5) Crimp the terminal

Thread the bare "④ copper core conductor" into the terminal and use manual hydraulic crimping pliers or electro-hydraulic crimping pliers to crimp the cable lug. The cable after crimping is shown below:

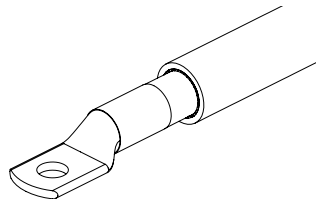

(6) Cover the heat shrink tube

Cut the length of 60-100mm heat shrink tube (red and black), refer to the color of the existing heat shrink tube at the end of the cable, put the red and black heat shrink tube on the corresponding cable respectively (red-red, black-black corresponding set), put the cable lug and the cable "① outer sheath" together with the heat shrink tube, and fix the heat shrink tube with the heat gun (temperature 200°C). After the heat shrink tube is covered, the cable is shown below:

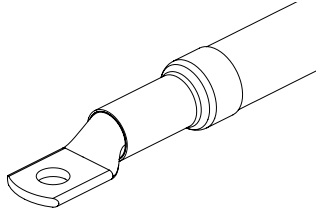

4.3 Cable connection

4.3.1 Cable connection at the bus bar

4.3.1.1 Required accessories and tools

- ① Bus bar
- ② Motor to bus bar power cable
- ③ Battery to bus bar power cable
- ④ Bus bar to DC-DC power cable
- ⑤ 3.3kW charger
- ⑥ M4 hex wrench, M6 hex wrench, M8 hex wrench

4.3.1.2 Installation

Install the cable according to the logo on the bus bar by following steps.

The corresponding relationship between the logo and functional interface is as follows:

- a.BAT - connected to G102 battery
- b.96V-1, 96V-2, 96V-3 - connect to the bus bar or other 102.4V electrical equipment
- c.CHG - connect to charger
- d.MOT - connect to the motor

(1) Remove the screws and top cover of the bus bar with an M4 socket wrench

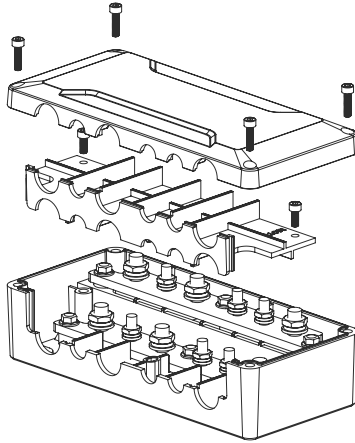

Figure 4-1 The disassembled bus bar

(2) Install the cable lug of 4 groups of cables

It is necessary to install 4 groups of cables (②, ③, ④ and ⑤) of 4.3.1.1, a total of 8 cables to the terminals on the top.

For the functions of each interface on the bus bar, see the corresponding logo of the interface.

1. Use M8 wrench and M6 wrench to unscrew the nut (a gasket is on the screw);
2. Install the positive cable (red sleeve) on the lower copper bar, the locking torque of M6 nut is 5N·m, the locking torque of M8 nut is 10N·m, ② connect MOT+, ③ connect BAT+, ④ connect 96V-2+ and ⑤ connect CHG+, as shown below after installation;

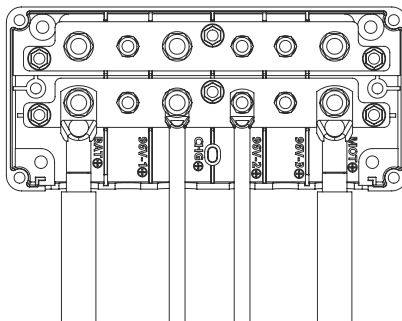

Figure 4-2 Wiring position of the positive terminal at the bus bar

3. After installing the positive cable, install and lock the positive and negative baffles with screws;
4. Install the negative cable (black sleeve) on the upper copper bar, the locking torque of M6 nut is 5N·m, the locking torque of M8 nut is 10N·m, ② connect MOT-, ③ connect BAT-, ④ connect 96V-2- and ⑤ connect CHG-, as shown in Figure 3 after installation;

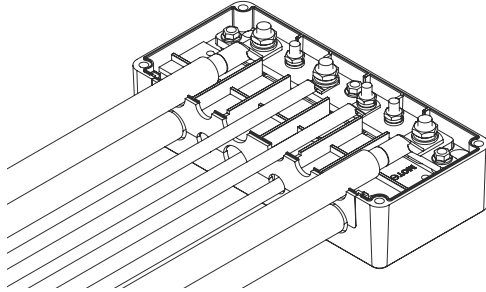

Figure 4-3 Negative wiring position of the bus bar

5. Bus bar installation: The bus bar shall be fixed with M6 self-tapping screws or bolts based on the actual installation position, and the M6 fastening torque is 8N·m. The bus bar needs to be installed on a flat plane, and it needs to be far away from the position with water risk and heat source.



Connect the positive and negative power terminals of the battery to the positive and negative power terminals of the motor. Do not reverse connect the positive and negative terminals. After connecting the cables, please confirm the correctness of the connection.

(3) Use screws to fix the bus bar top cover

After the bus bar is installed, the overall state is shown below.

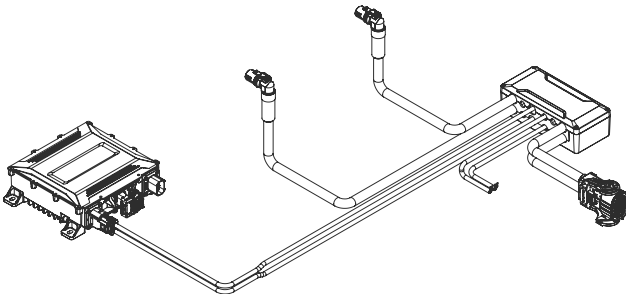

Figure 4-4

4.3.2 Connect the DC-DC module

4.3.2.1 Required accessories and tools

- ① The part of the bus bar completed in Step 4.3.1
- ② Phillips Screwdriver
- ③ DC-DC to 12V battery power cable

4.3.2.2 Installation

(1) Connect the bus bar to the DC-DC module

Remove the transparent protective cover of the DC-DC terminal.

Using a phillips screwdriver, first loosen the bolts of the DC-DC module terminals (no need to unscrew the bolts), and then bend the 90 ° U-shaped terminals at the tail of the thinner red and black second wires in the bus part completed in step 4.4.3.1, insert into the DC IN + V and -V terminals of the DC-DC module according to red + V and black -V, and tighten the bolts. The state after installation is shown in Figure 5.

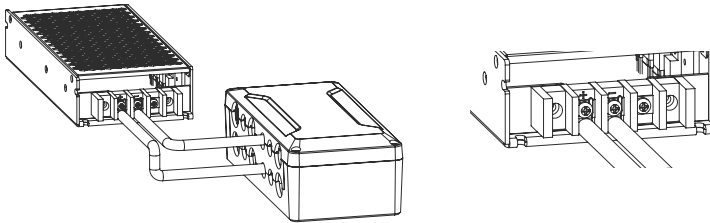

Figure 4-5 Completed connection of the bus bar +DC-DC module

(2) Install the DC-DC to 12V battery power cable to the DC-DC module

Using a phillips screwdriver, bend the 90 ° U-shaped terminal at the end of ③ "DC-DC to 12V battery power cable", insert it into the DC OUT + V and -V terminals of the DC-DC module according to red + V and black -V, and tighten the screwdriver. The state after installation is shown below.

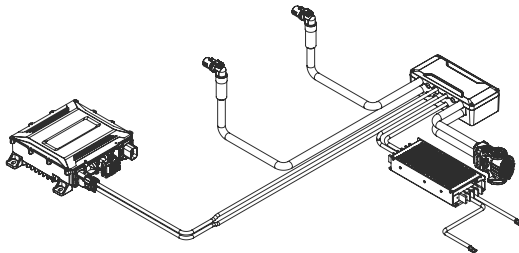

Figure 4-6 DC-DC module after installation

4.3.3 Connect the G102-100 Battery

4.3.3.1 Required accessories and tools

- ① G102-100 battery
- ② The bus bar connected in Step 4.3.1

4.3.3.2 Installation

(1) Connect the bus bar to the G102-100 battery

Plug the aviation plug of the bus bar portion into the corresponding color port on the G102-100 battery.

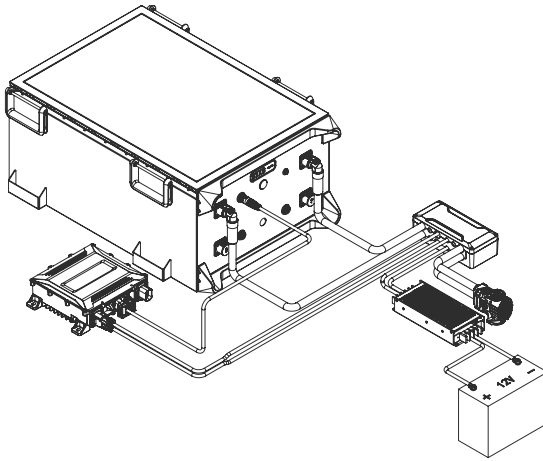

Figure 4-7

4.3.4 Connect the DC-DC module to the 12V battery

4.3.4.1 Required accessories and tools

- ① 12V battery (user supplied)
- ② Wrench for 12V battery
- ③ The DC-DC module completed in step 4.3.2

4.3.4.2 Installation

(1) Connect the DC-DC module to the 12V battery

Install the cable drawn from the output end of the DC-DC module on the positive and negative terminals of the 12V battery according to the color of the cable red corresponding to the positive terminal and black corresponding to the negative terminal.

4.3.5 Connect the power cable of the motor of the ship

4.3.5.1 Required accessories and tools

- ① Motor
- ② The connection of the bus bar, DC-DC module, 12V battery completed in step 3.3
- ③ M8 hex socket screws and nuts
- ④ M8 hex wrench

4.3.5.2 Installation

(1) Connect the power high-voltage power cable of the motor

Connect the orange self-locking plug in the bus bar section obtained in Step 4.3.1 to the orange plug pair that comes with the motor.

The steps are as follows:

Open the lock of the orange self-locking plug and push up the black handle, as shown below.

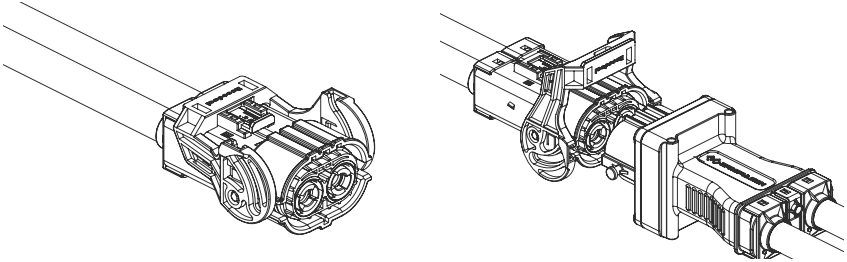

Figure 4-8 High voltage interlocking plug

Insert the orange self-locking plug into the orange junction box at the end of the machine and insert the card point into the gap on the black handle, as shown below.

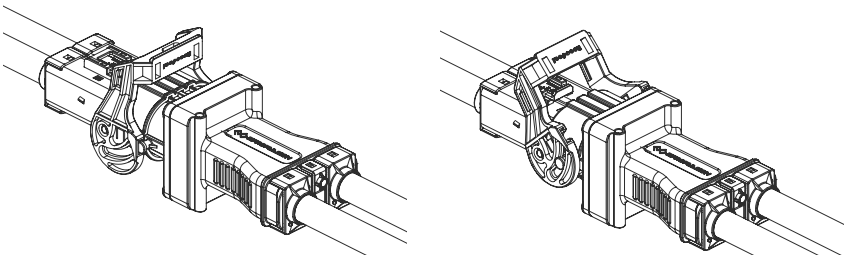

Figure 4-9 High voltage Interlocking plug

Press down on the black handle, using the black handle to make the connector fit tightly and close the latch, as shown below.

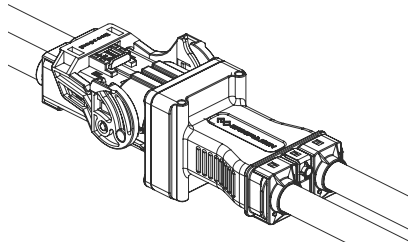

Figure 4-10 High Voltage Interlock Plug

(2) Connect the 12V power cable

Connect the red and black wires drawn from the machine to the positive pole of the 12V battery according to the red cable, and the black cable to the negative pole of the 12V battery, and connect to the 12V battery terminal post, and lock the terminal post nut. (Note: The 12V battery should be placed close to the motor on the ship)

 After the installation of the above steps, the status is shown below.

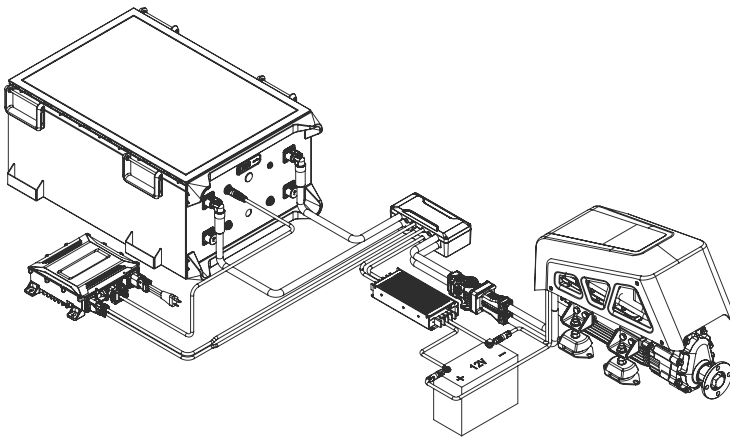

Figure 4-11

4.3.6 Connect interactive devices and accessories

(Smart throttle, smart display, external GPS module, 4G antenna, G102-100 battery)

4.3.6.1 Required accessories and tools

- ① Smart throttle ×1;
- ② Smart display ×1;
- ③ External GPS module ×1;
- ④ G102-100 battery ×1;
- ⑤ Communication cable ×3;
- ⑥ Communication extension cable ×1
- ⑦ 5-way T-connector ×1 & 3-way T-connector ×1 (or 3-way T-connector ×4)

4.3.6.2 Installation

(1) Assemble the T-connector

Attach one 5-way T-connector to one 3-way T-connector and tighten the nut. (or attach 4 3-way T-connectors together)

(2) Connect interactive devices and other accessories

Connect each part and cable together corresponding to the number and the figure below:

1. The 10m communication cable of the I-series inboard motor;
2. 5-way T-connector ×1 (or 3-way T-connector ×3);
3. 3-way T-connector ×1;
4. Communication terminator;
5. Communication cable 1m (one connector is 90° elbow, and is connected to the MOTOR interface of smart throttle, smart display or G102 battery);
6. The cable of the external GPS module;
7. Communication extension cable 10m.

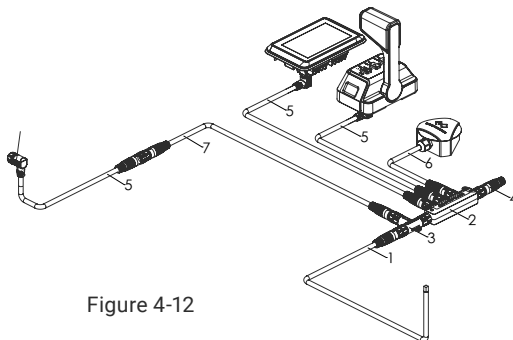
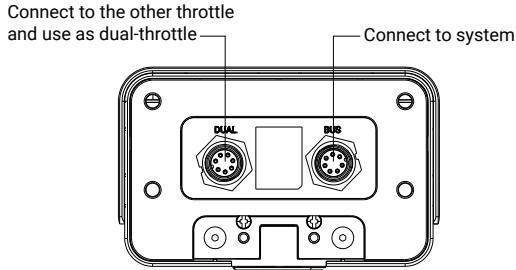

Figure 4-12

After the interactive device is connected, the thread of each connector should be tightened to ensure stability and waterproof.

(3) Connection of smart throttle

BUS port and **DUAL** port are at the bottom of smart throttle.



The cable connections for specific application scenarios are as follows:

- Single-throttle operation

The **BUS** port on the smart throttle is connected to the CAN bus. The **DUAL** port must be suspended.

- Dual-throttle operation

Connect the **BUS** port of the 1# smart throttle to the CAN BUS. Connect the **DUAL** port of the 1# smart throttle with the **DUAL** port of the 2# smart throttle. The **BUS** port of the 2# smart throttle must be suspended.

(4) Installation of 4G antenna

1. Remove 8 M5×12 hexagon flat head screws (3 on each side of the cover and 2 on the rear side) using a 3mm hex wrench, and remove the I-10 cover;

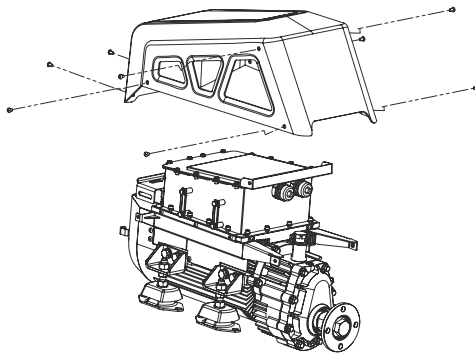



If the cover has been removed when hoisting, then this step can be ignored.

2. Connect the SMA male at the end of the 4G Antenna to the corresponding interface of the drive module, and install the I-10 cover after confirming tightening;

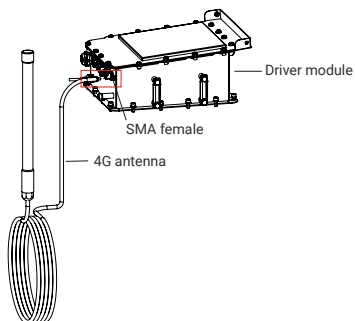

3. Install and fix the 4G Antenna on the ship (outdoor). There are two ways to fix it, as shown in the following figure.

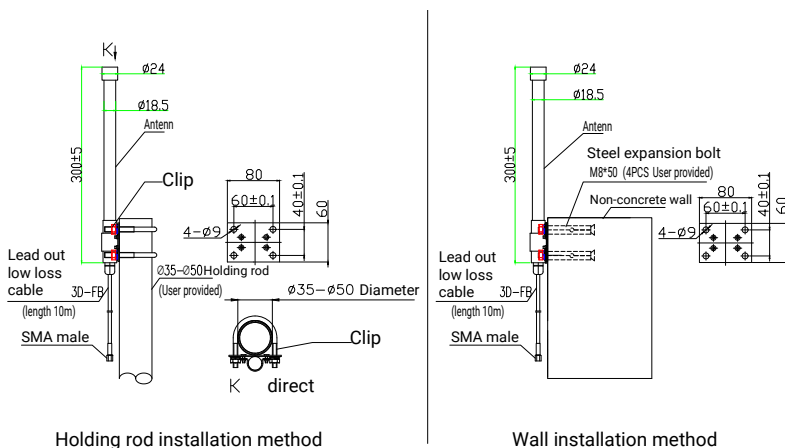

- Pole installation: The customer provides a vertical pole with an external diameter of $\varphi 35 \sim \varphi 50 \text{mm}$, and then the 4G Antenna can be held tightly on the vertical pole through the supporting clip code.
- Wall installation: Customer provides 4 M8x50 steel expansion bolts, and the 4G Antenna can be fixed on the non-concrete wall through these 4 bolts.

(5) GPS external module installation

1. Connect the communication port of the GPS external module to the T-connector;
2. Install and fix the GPS external module on the ship (outdoor). There are two specific fixing methods, as shown in the figure below:

- **3M adhesive stick fixed**

Glue the sealing cover plate fixing adhesive of the accessories to the specified area at the bottom of the GPS external module, and paste it in an open outdoor area. Before pasting, ensure the cleanliness of the pasting position to avoid improper pasting due to impurities at the pasting position.

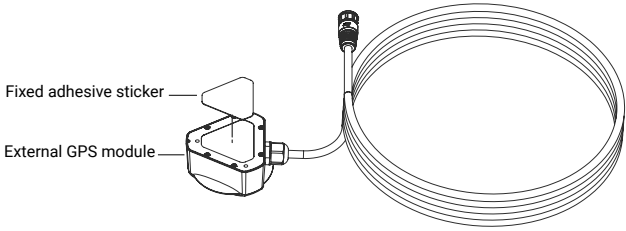

- **Self-tapping screw fixation**

Open the decorative cover of the GPS external module, fix the GPS external module in an open area outside with the 3 M3 self-tapping screws of the accessory. After confirming that the 3 self-tapping screws are locked, finally fasten the decorative cover on the GPS cover in the same direction as the logo.

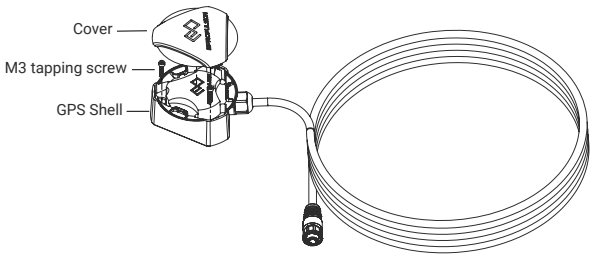
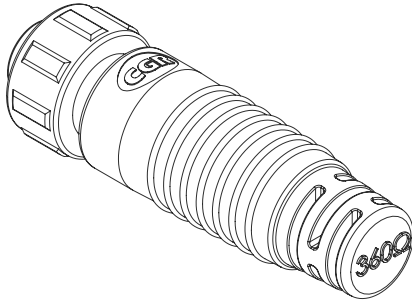

Figure 4-14 Connection relationship between interactive device and T-connector

4.3.7 Connection of communication terminator

In the process of using the onboard machine, in order to make the communication between the various components more stable, it is necessary to connect different combinations of end point resistors on the T-connector combination according to the following scenarios. The end point resistance value is marked at the tail of the end point resistance, as shown in the figure:



(1) Single-machine

Please connect a communication terminator marked "120Ω" to the T-connector.

(2) Dual-machine

Please connect two communication terminators marked "360 Ω" to the T-connector.

(3) Triple-machine

Please connect a communication terminator marked "360Ω" to the T-connector.

(4) Quad-machine

There is no need to connect the communication terminator to the T-connector. Please use the waterproof cap that comes with the T-connector to cover the T-connector interface.

4.3.8 Status after connection

It is recommended to place each module in the actual installation position on the ship before connecting the cable. The cable marked as "1", "2", "3" and "4" in Figure 15 can be properly expanded or coiled according to the actual position and distance of each module.

The part labeled "1" in FIG. 15 can be properly unwound or rewound according to the position and distance between the motor on the ship and the busbar and G102 battery.

The section labeled "2" in FIG. 15 can be properly expanded or rewound according to the position and distance between the motor on board and the control console.

The part labeled "3" in FIG. 15 can be properly expanded or rewound according to the position and distance between the control console on board and the G102 battery.

The part marked as "4" in FIG. 15 can be properly expanded or rewound according to the position and distance between the control console on board and the external GPS module.

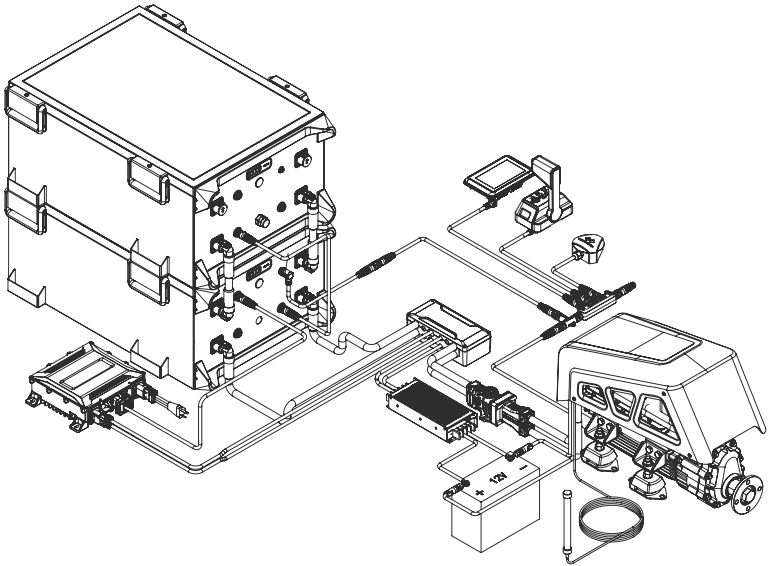

Figure 4-15 State of cable after completion of connection



All the above operations prohibit live work, live plug.



5 Operation

5.1 Smart Throttle Button Description

- Single-throttle operation

Button	Function
Power	<p>Power on and off the system: When the motor is turned off, long press the Power button for 1 second to start the motor. When the system is turned on, long press the Power button for 1 second to stop the motor.</p> <p>Switch console: When the system is turned on, press the Power button twice on the inactive console to activate it.</p>
Hold	<p>Direction holding function or anchor mode: Press twice to enter Hold mode, and press once in Hold mode to exit the mode.</p>
Dock	<p>Power limit mode: Press once to enter Dock mode, and press once to exit Dock mode only when the throttle is in the Neutral position.</p>



The factory default is Starboard mode. If you need to switch to Port mode, please refer to the Smart Display 5" or motor user manual and click the Smart Display to switch.

Button	Function
	<p>When pressing the button, the electric tilt and trim starts to raise and stop when releasing the button.</p>
	<p>When pressing the button, the electric tilt and trim starts to lower and stop when releasing the button.</p>

- Dual-throttle operation

Button	Function
Power	Power on and off the system: When the motor is turned off, long press the Power button for 1 second to start the motor. When the system is turned on, long press the Power button for 1 second to stop the motor. Switch console: When the system is turned on, press the Power button twice on the inactive console to activate it.
Hold	When pressing the button, the electric tilt and trim starts to lower and stop when releasing the button.
Dock	Power limit mode: Press once to enter Dock mode, and press once to exit Dock mode only when the throttle is in the Neutral position.
1Lever	1 lever control mode: Press once to enter the left lever control mode. Press twice to enter the right lever control mode again. Press third to exit the 1 lever control mode. 1Lever mode can only be entered or exited when all levers are in the Neutral position.
Turbo	Turbo mode: Press twice to enter Turbo mode, press once in Turbo mode to exit the mode.
FN	ction button: Press once to enter to activate the function, and press again to exit the function. For specific function configuration, please use the Smart Display to select.

Dock and Turbo modes cannot be accessed at the same time.

Button	Function
	When pressing the button, the electric tilt and trim starts to raise and stop when releasing the button.
	When pressing the button, the electric tilt and trim starts to lower and stop when releasing the button.



Note: The kill switch is placed correctly.

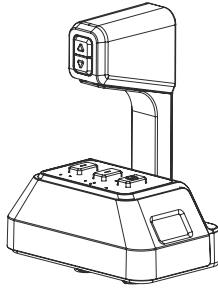

- Please place a kill switch on either side of the Smart Throttle to start the motor.
- Please remove the kill switch after the machine is turned off.
- Stop the inboard motor in emergency by detaching the kill switch.
- To run the motor again, first attach the kill switch, then start the motor.

5.2 Start the Machine

5.2.1 Boot Operation

Long press the Power button for 1s to start the system. When the smart throttle panel lights up, the system is started.



After powering on the system, wait until the Power button light is steady green and the smart display "READY" lights up before driving.

5.2.2 System problem feedback method after startup

If the smart throttle chirps after the system is started and the display displays an error message, refer to 5.8 Troubleshooting to solve the problem.

5.3 Perform initial configuration

Step 1: Read the device

After all accessories are assembled, power on, turn on the smart throttle, the Smart display will automatically read the SN of the device when it is turned on.

Manually check whether the SN of all parts on board is displayed on the display. If the check is correct, click Confirm; If SN of any part is not displayed, Check the connection of parts on the ship is normal and click Check again. The system will read it again.

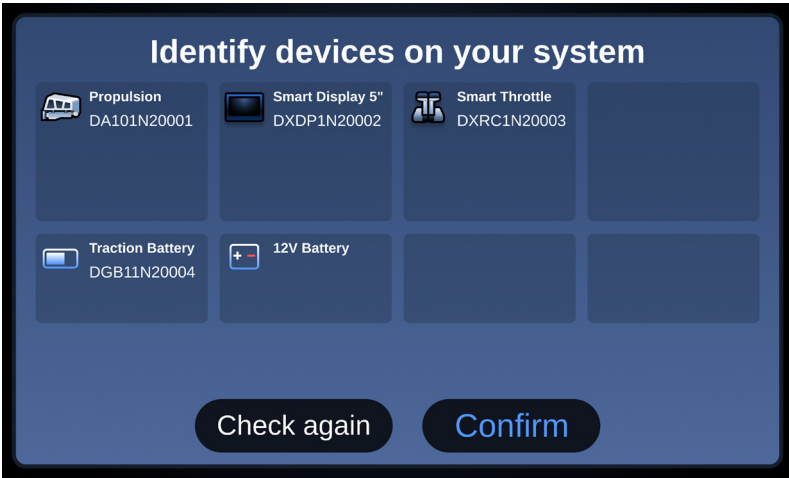

Step 2: Configure the location of the equipment

When there is only one console and one propulsion, the system will automatically complete the system initialization settings and directly enter the home page.

When there are more than one console and more than one propulsion, the user needs to configure the console accessories and the position of the propulsion. The following illustrates the configuration process with two sets of consoles and two motors.

1. Configuration display

When there are two consoles, the display will display two consoles. By default, the console where the current display is located is Console A.

2. Configure smart throttle

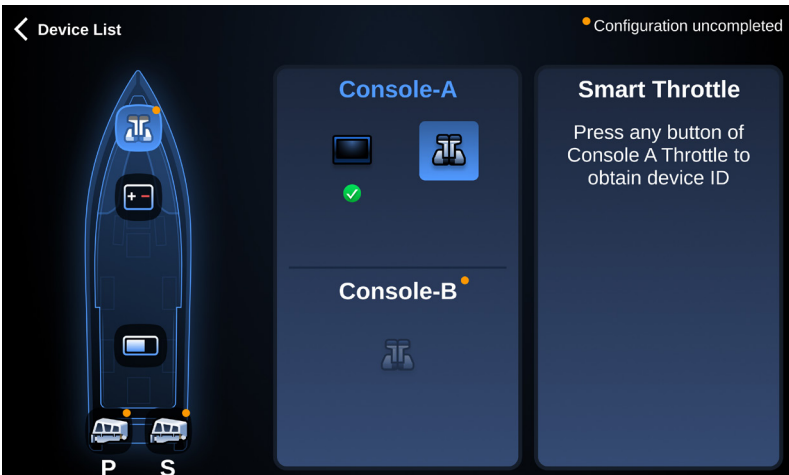

When it is a single-throttle, manually click any button of the throttle to match successfully. When it is a dual-throttle, click any button of the left and right throttles respectively to match successfully.

3. After console A is configured, the remaining parts will be automatically matched to console B.

4. Configure motors

Click the SN of the motor to configure the port and port sides of the motor.



5.4 Home Page



No.	Function	Description
1	Setting page	Click to go to the setting page.
2	Home page	Click to go to the home page.
3	Propulsion page	Click to go to the propulsion page.
4	Warning	When the system fails, it will prompt a fault icon, with the number representing the number of faults.
5	System status	READY indicates that the system is ready to start.
6	4G network signal strength	
7	Travelled time/distance	You can switch between distance and time in the settings for the travelled time/distance of this trip.

No.	Function	Description
8	Battery indicator bar	The indicator changes with battery level.
9	Battery level	Battery level
10	Remaining distance or time	The remaining distance/time supported by the current battery level. You can switch between distance and time in the settings.
11	Compass	/
12	Power indicator	When it reach the rated power, it is full grid. The indicator will change accordingly when the power changes.
13	Current power/Current RPM	You can switch between current power or current RPM in the settings.
14	Gear	F: Forward gear N: Neutral R: Backward gear
15	Speed	Current speed, which can be switched between KNOTS, KM/H, and MPH in the settings.

5.5 Powertrain diagram

5.5.1 Control console



Click on the console to view the accessories for each console.

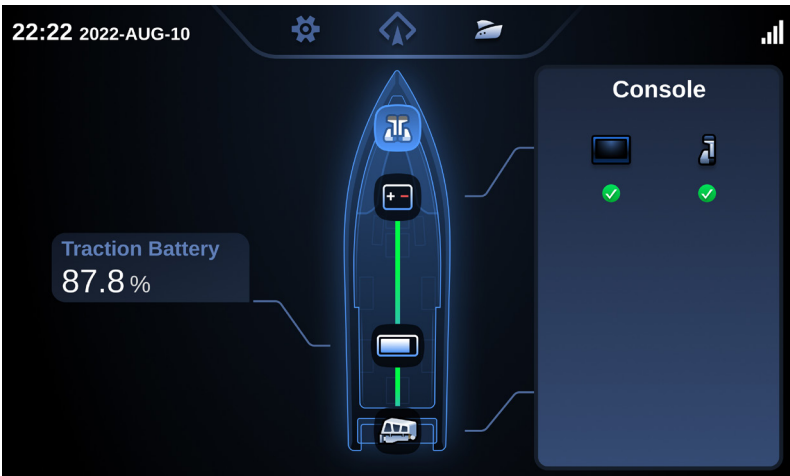
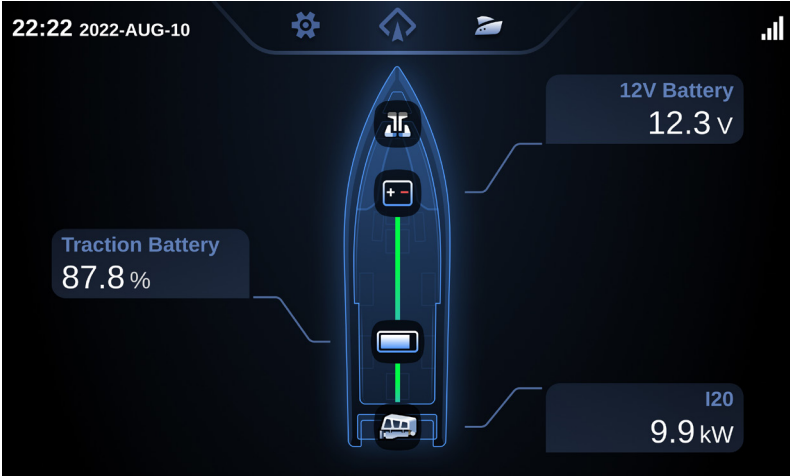

When the accessories fail, the icon will turn orange or red. Click the fault icon to view the detailed fault.

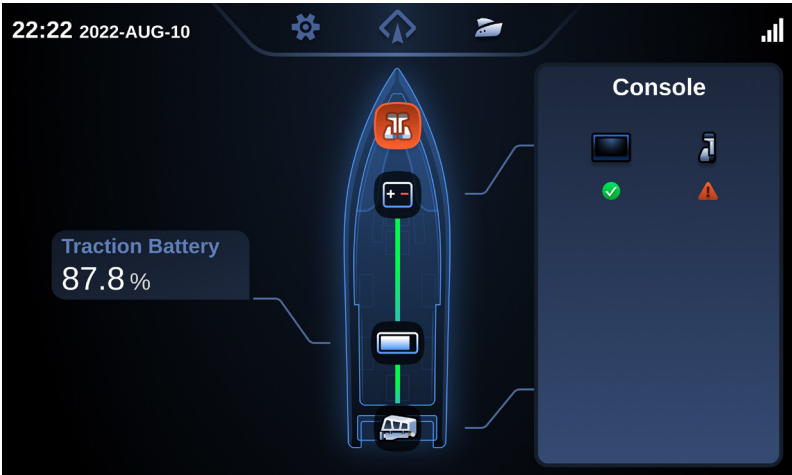

5.5.2 Power Battery



The power battery can be clicked to view the remaining power, voltage, and current.

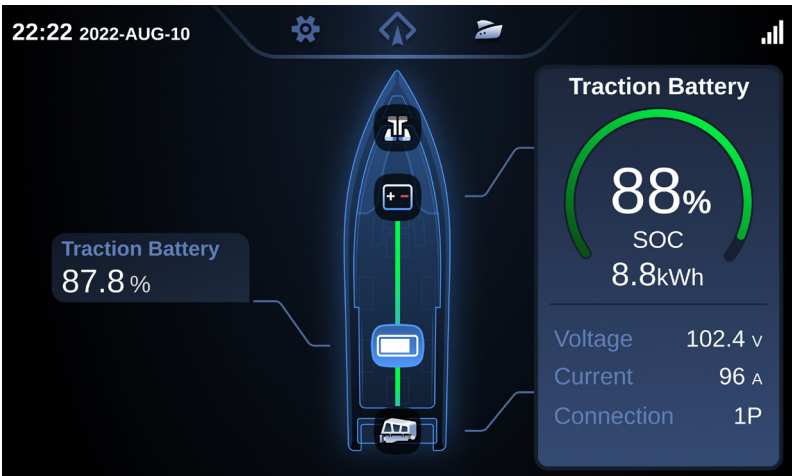

5.5.3 Propeller



Motors can be clicked to view current power, rotational speed and accumulated running time since the last maintenance.

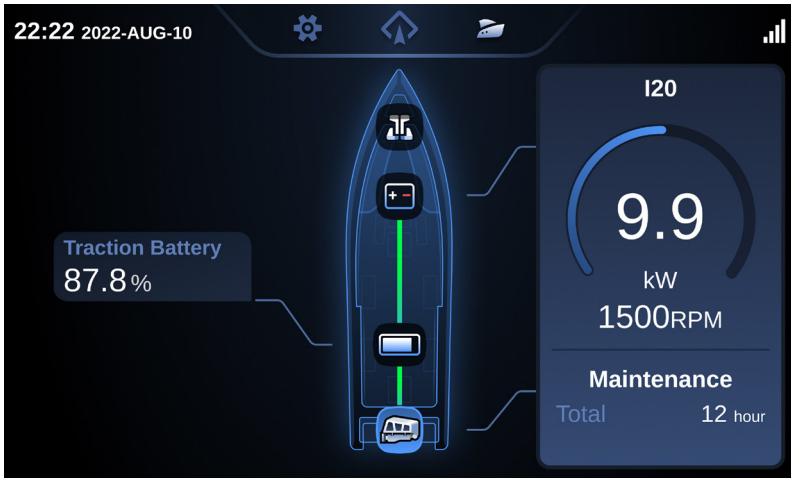

5.6 Setting

The Settings include three major module Settings: motor Settings, control console Settings, and general Settings.

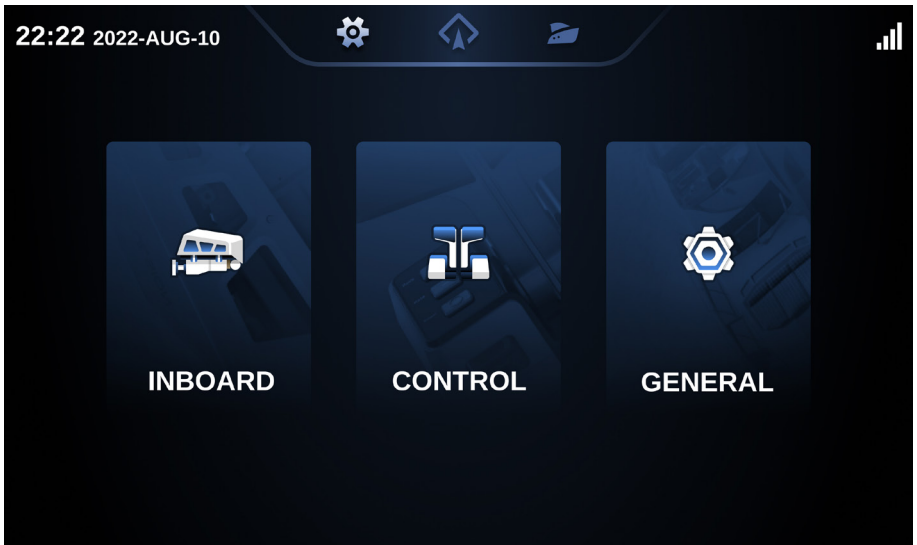

Button	Function
INBOARD	Click to enter the propulsion setting page, you can set the motor switch and reverse propeller switch.
CONTROL	Click to enter the console setting page, you can set single-throttle assembly, dual-throttle FN function, Smart display, etc.
GENERAL	Click to enter the general setting page to set firmware update, maintenance, connectivity and more.

5.6.1 Propulsion Setting

5.6.1.1 Propulsion switch

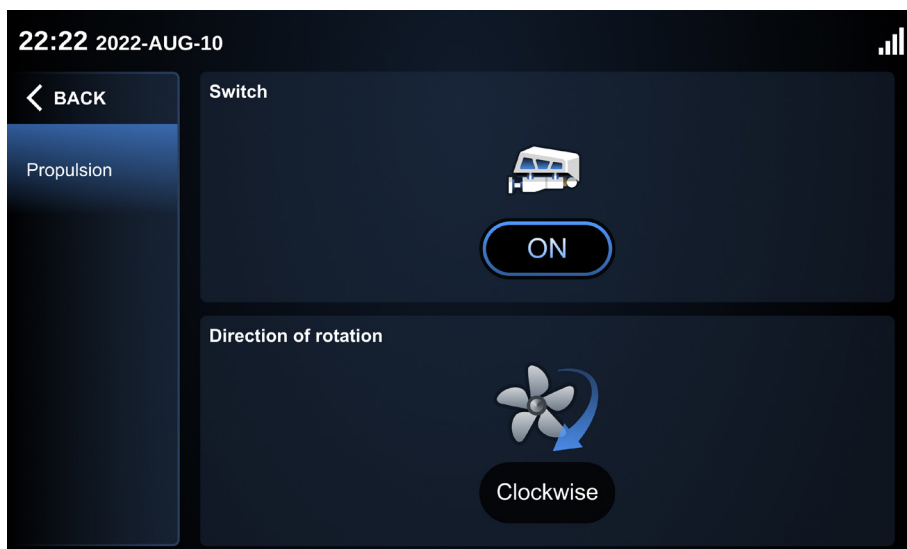

Button	Function
Motor switch	Click to switch on or off the motor. If the switch springs back, the setting has failed.
Direction of rotation	Click to switch the rotational direction of the propeller. If the switch bounces back, the setting fails.

5.6.2 Control console Settings

5.6.2.1 Smart throttle settings

1. Single-throttle Settings

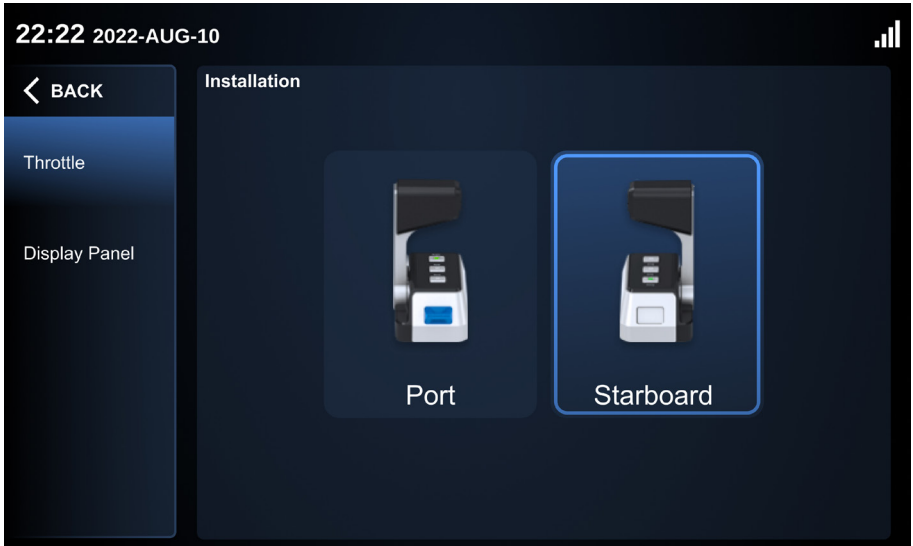

Button	Function
Starboard	Click and set the smart throttle installation mode to starboard installation. If it springs back, the setting fails.
Port	Click and set the smart throttle installation mode to port installation. If it springs back, the setting fails.

2. Set dual-throttle

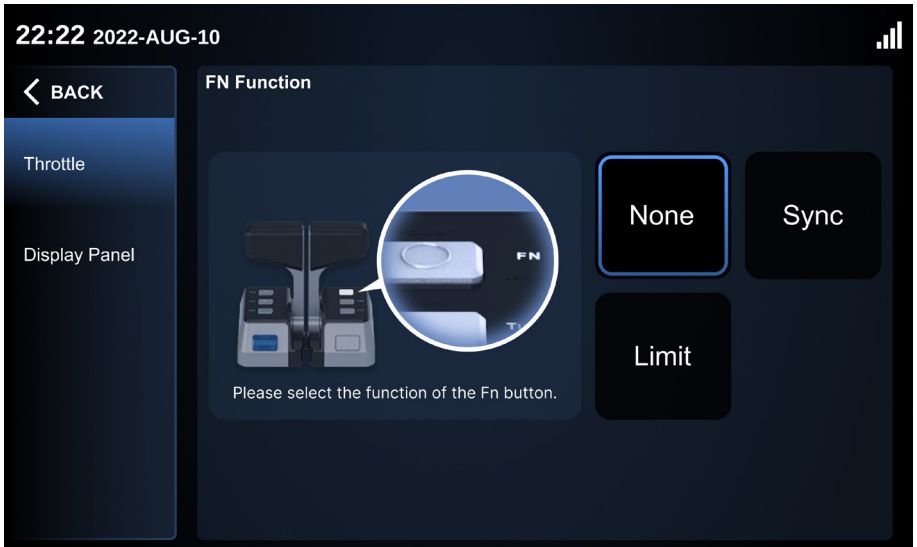

Button	Function
None	Set the FN function of smart throttle as invalid after clicking.
Sync	Set the FN function of smart throttle to sync left and right handle after clicking. When the throttle values of the left and right throttle are not much different, the system will forcibly synchronize the throttle values of the two sides into one value. When the throttle values of the left and right throttle differ greatly, the respective throttle values of the two rockers are maintained.
Limit	After clicking, set the smart throttle FN function to limit speed. The maximum speed of the limit can be customized on the Settings page.

5.6.2.2 Display settings

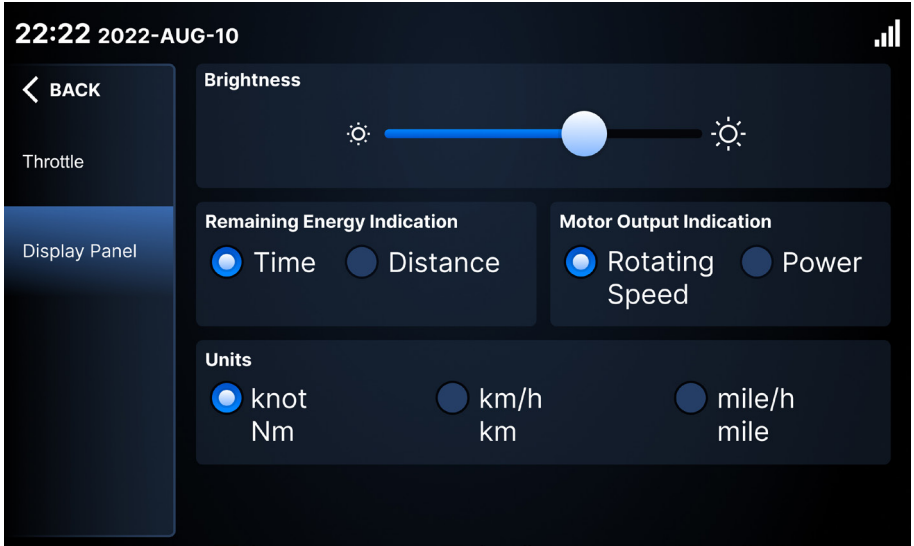

Button	Function
Brightness	Drag to adjust the brightness of the display. This setting is still saved after powered off.
Remaining energy indication	Switch between the time and distance to remaining energy, and the home page will change accordingly after the switch.
Motor output indication	Switch between the rotating speed and power of the motor, and the home page will change accordingly after the switch.
Unit	The unit can be switched between knot, km/h and mile/h. After the switch, the speed limit unit of the home page and ePropulsion setting page will be changed accordingly.

5.6.3 General setting

5.6.3.1 System firmware information



Button	Function
System version	Display the propulsion version.
Serial number	Click Device List to go to the device serial number list page. You can view all device SN and software and hardware version.
New version update	<p>When there is a new version to be updated, you will be prompted with the content of the new version and the estimated time. Users can choose to update immediately or in the early morning. If they choose to update in the early morning, they will be updated at 02:00 of the next day.</p> <p>Note:</p> <ol style="list-style-type: none">1. Update must meet two conditions: 1) 12V supply voltage > 10V; 2) The system has no operating power.2. The system cannot run during the update process, so it is recommended to choose early morning update or update when the ship is not needed.

Device list page

1. Click Reset to reset the device to its factory device state.
2. Device List displays the SN and software and hardware versions of all components of the propulsion.



5.6.3.2 Maintenance - All maintenance timing tips

1. The period of maintenance is 220 hours and the system will automatically calculate the maintenance countdown based on the accumulated running time since the last maintenance.
2. After the maintenance time is reached, the user will click the reset button and the countdown will be reset to 220 hours.

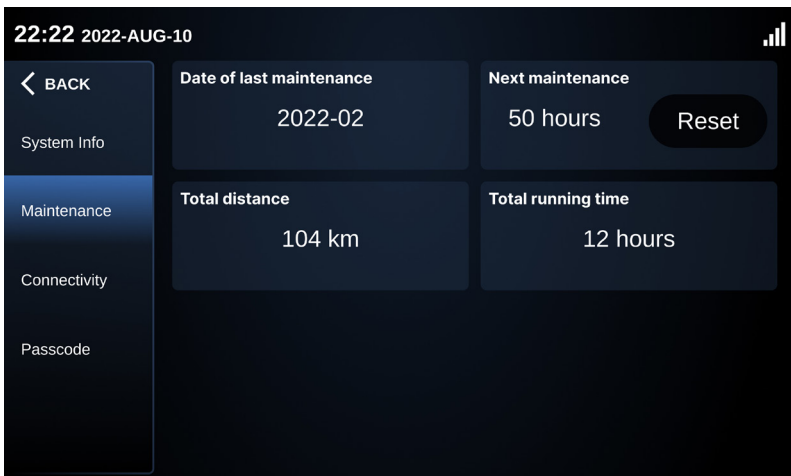

5.6.3.3 ePropulsion Connectivity Service

Register in the ePropulsion Link account with your mobile phone, and when you add a new boat, you can scan the code to bind the power system.

ePropulsion Link is a software product developed by ePropulsion, which provides shipowners with major functions such as boat status monitoring, voyage log management and firmware upgrades.



5.7 Connectivity

I-20 inboard motor has the ePropulsion connectivity service, you can connect the motor to ePropulsion Connectivity Service, so that you can remotely check the ship status and propulsion system status.

5.7.1 Mobile application

You have 2 softwares that can access the motor, ePropulsion Link for individual boat owners and ePropulsion Fleet for fleet management, which will bring you rich features:

- See your speed and location in real time
- View power and charging status in real time
- Create geofencing and speed monitoring
- Automatically generates trip history and ship reports
- Remote Visitor authorization
- Co-Owner access
- Set up SMS notifications

< I-20 Connected

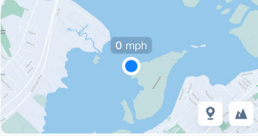

0 mph

I-20

On

Power battery

60 %

12V Battery

11.7 v

Boat
Trips
Notifications
Settings

Testing Fleet

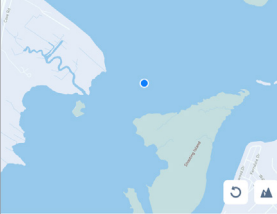

I-20

40%

Fleet
Trips
Notifications
Settings

Total Duration

Total Trips

24.2 km

19

Check Boat Report

Mar 15, 2023 - Apr 10, 2023

Apr 3, 2023 17:18

1.1 km	0 h 7 m	9 km/h
Distance	Duration	Avg. Speed

Mar 28, 2023 17:08

1 km	0 h 13 m	4 km/h
Distance	Duration	Avg. Speed

Mar 28, 2023 11:26

0.0 km	0 h 6 m	0 km/h
Distance	Duration	Avg. Speed

Mar 24 2023 17:08

Boat
Trips
Notifications
Settings

< Trip history

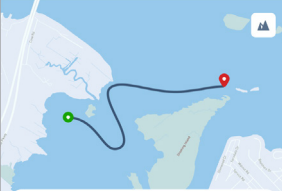

I-20

Mar 28, 2023 17:08 - Mar 28, 2023 17:22

Distance	1.0 km
Duration	0 h 13 m
Consumption	2.7 kWh
Avg. Speed	4 km/h
Max. Speed	13 km/h

Distance	1.0 km
Duration	0 h 13 m
Consumption	2.7 kWh
Avg. Speed	4 km/h
Max. Speed	13 km/h

Speed

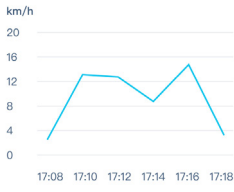

km/h

17:08 17:10 17:12 17:14 17:16 17:18

Share this trip

5.7.2 How to connect

1. Log in to the websites.

- a. ePropulsion Link: <https://link.ePropulsion.com>
- b. ePropulsion Fleet: <https://fleet.ePropulsion.com>

2. Sign up for your account.

- a. Click the Sign Up button to sign up for your account
- b. Please use your usual email address to register, so that you can retrieve your password if you forget it.
- c. Enter relevant information (Email, Name, Password, Confirm Password) and click Send Code to receive Verification Code.
- d. Enter Verification Code, click Agree to Terms of Use and Privacy Poilcy, and click Sign Up to complete registration.

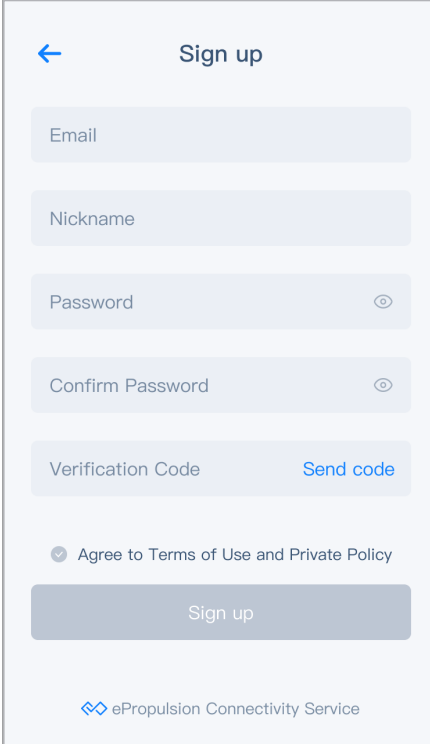

The image shows a mobile application screen for signing up. At the top left is a blue back arrow, and at the top center is the title "Sign up". Below the title are five input fields: "Email", "Nickname", "Password" (with an eye icon to toggle visibility), and "Confirm Password" (with an eye icon). Below these fields is a "Verification Code" field with a "Send code" link to its right. Underneath is a checkbox labeled "Agree to Terms of Use and Private Policy". At the bottom is a large grey "Sign up" button. At the very bottom of the screen is the ePropulsion logo and the text "ePropulsion Connectivity Service".

3. Add new boat

After logging in to the home page for the first time, click Create Boat button to enter relevant information (Boat Name, Boat Brand, Model, Registration Number). Boat Name is mandatory. Before creating boats in ePropulsion Fleet, it is necessary to create a fleet first, which can be completed according to the App prompts.

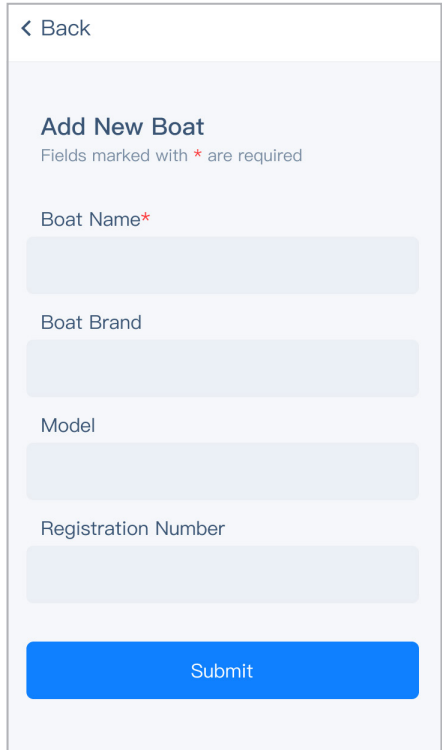

< Back

Add New Boat

Fields marked with * are required

Boat Name*

Boat Brand

Model

Registration Number

Submit

4. Connection

- a. After completing the boat information entry, click the Connect Now button on the home page to enter the boat connect page.
- b. There are two ways to connect the boat to the propulsion.
 - (1). Click the Scan button to scan code on the display (Click the Setting button -> General -> Connectivity on the display to view the QR code of the propulsion).
 - (2). Click Manually enter the connectivity ID. By entering the ID on the display.

After the connection is successful, you will see a prompt indicating that the connection has been successful and can see information such as the current boat's location and power level.

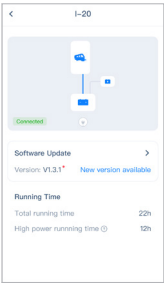
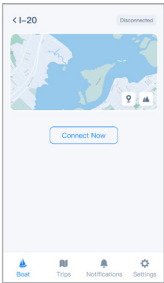
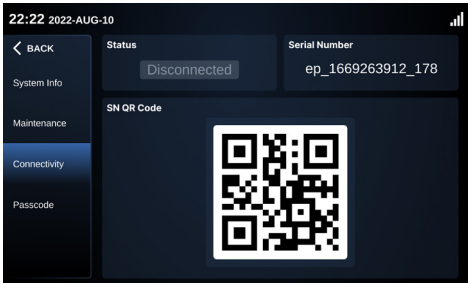

You can use the Add to Home Screen feature for iOS and Android systems to pin the Bookmark to the first screen for quick access.

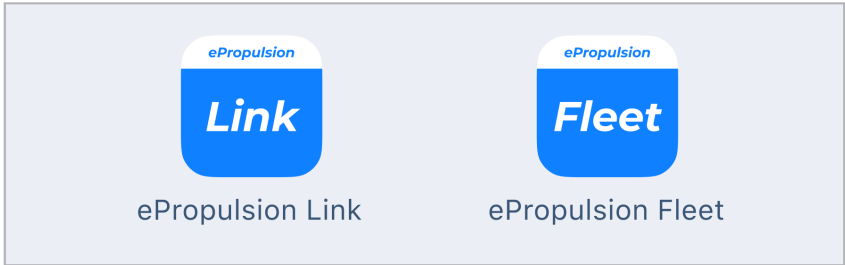

5.7.3 OTA update

An over-the-air (OTA) update is the wireless delivery of new software or firmware to local devices. Conduct regular updates, including introducing new features - OTA updates improve user experiences. Boat owners also save time and money as well remote software updates mean they don't need to visit a dealership physically.

1. Receive OTA notification

- a. The display will receive OTA update notifications with the ePropulsion Link as well as the ePropulsion Fleet.
- b. The ePropulsion Link and ePropulsion Fleet will be notified of OTA updates on the Notifications page.
- c. The display will be notified of the new version on the Settings page -> General -> System Info.

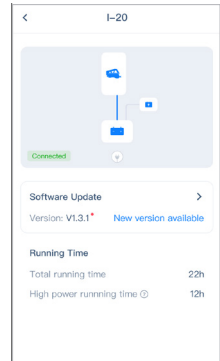

2. Select OTA mode

- a. Update via display
 - (1). Click the Update Now button on the Settings page -> General -> System Info to perform the OTA update immediately.
 - (2). On the Settings page -> General -> System Info click Update Tonight and the OTA update will take place at 2am.
- b. To update via software, click on the Notifications page to go directly to the corresponding feature page, where you can select from
 - (1). Click the Install Now button to perform OTA update immediately.
 - (2). Clicking the Install Tonight button will start the OTA update at 2 a.m.

3. Complete OTA update

- a. After the binding is successful, you will see a message indicating that the binding is successful. You can also see that the current software version is the latest version on the user's software and display.
 - (1). Display view: Settings page -> General -> System info interface to view the current software version
 - (2). User software view: Click the Power system box -> Power System details page to view the current software version

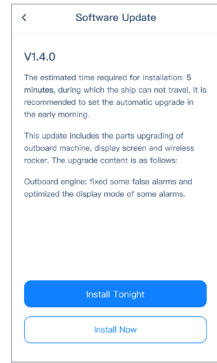

5.8 Motor operation

5.8.1 Start

1. Place the kill switch on the smart throttle.
2. Attach the buckle cord to your wrist or to your life jacket.
3. Press the Power button for 1 second to turn on, and do not drive until the Power light is steady green and the display "READY" lights up.

5.8.2 Adjust power

When the battery is well connected and switched on, power on the control system to start the inboard, then slowly push the throttle forward position to increase the power.



Before power on the smart throttle, please reset the throttle to zero position.

If you find a blinking "RESET" on the display panel, you are reminded to reset the throttle to zero position.

If you pull the throttle from the forward position to the backward position directly, the motor will first stop shortly, then start turning to the reverse direction.

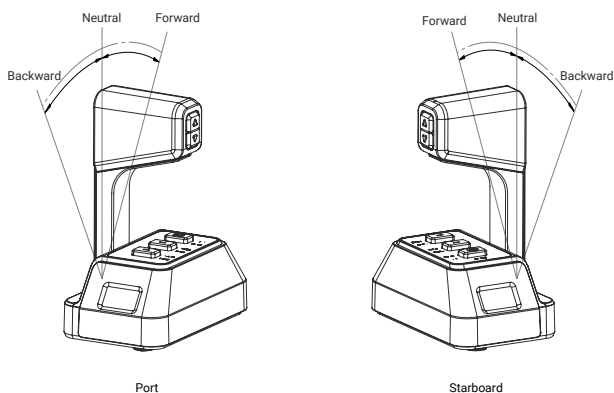

5.8.3 Stop

This product can be stopped in one of four ways

1. Turn throttle to zero position.
2. Remove the Kill Switch.
3. Switch off the power button.
4. Disconnect the power cable.

5.8.4 Notices

1. In abnormal situations like a fall over emergency, it's recommended to stop the inboard motor by removing the kill switch from the smart throttle.

In malfunction situations, the inboard motor will stop immediately for protection. The inboard motor will stop if one of the following situations occurs.

1. The throttle is in zero position.
2. The power button is switched off.
3. The kill switch is removed.
4. The connection between tiller and battery is cut.
5. The battery is empty.
6. The inboard motor malfunctions (e.g.the motor is blocked or the battery voltage drops below 33V).

2. Rotating parts can cause severe injury or death. Never wear jewelry, unbuttoned cuffs, ties or loose-fitting clothing and always tie long hair back when working near moving/rotating parts such as the flywheel or PTO shaft. Keep hands, feet and tools away from all moving parts.



3. Some of the machine surfaces become very hot during operation and shortly after shutdown. Keep hands and other body parts away from hot machine surfaces.



5.9 Troubleshooting

5.9.1 Mechanical faults

A	B	C
Fault	Cause	Operation
Abnormal noise	Cover bolts are loose	Tighten
	Deflector bolts are loose	Tighten
	Fan bolts are loose	Tighten
Abnormal vibration	The output shaft of the motor	Adjust the output shaft position
	Loose parts or fasteners	Maintenance or replace
	Loose parts or fasteners	Tighten
Fan stalled	Abnormal control/fan damage	Check or replace
Over-temperature alarm	The air deflector of the host is too dusty and the heat dissipation is poor	Clean

5.9.2 System faults

Module	Fault		Solution
Drive motor	Encoder fault	P101003	<ol style="list-style-type: none"> 1. Check the external wiring. 2. Replace the rotary encoder. 3. Replace the motor controller.
	Power tube pass-through failure	P100F03	<ol style="list-style-type: none"> 1. Check the external wiring. 2. Check the insulation of the motor. 3. Replace the motor controller.
	Motor overdrive	P101113	<ol style="list-style-type: none"> 1. Check the operating conditions 2. Replace the rotation 3 Replace the motor controller
	Storage data failure		Replace the motor controller.
	Emergency stop	P101603	Check whether the emergency stop button is pressed
	The bus is overcurrent	P100C03	<ol style="list-style-type: none"> 1. Check the operating condition 2. Check whether there is short circuit in the power supply of the system
	The phase current overcurrent hardware is faulty	P100C03	<ol style="list-style-type: none"> 1. Check the operating condition 2. Check whether there is short circuit in the power supply of the system
	The phase current overcurrent software is faulty	P100D03	Check the operating condition
	Blocked	P101203	<ol style="list-style-type: none"> 1. Check the operating conditions 2. Overhaul the transmission system;
	The generator is severely overvoltage	P100603	Check the high voltage supply circuit.
	The generator is severely undervoltage	P100813	<ol style="list-style-type: none"> 1. Check the battery SOC 2. Check the status of the main contactor
The generator is generally overvoltage	P100712	Check the high voltage supply circuit.	

Module	Fault		Solution
Drive motor	The generator is generally undervoltage	P100912	Check the battery SOC
	The MOS is severely overtemperature	P100003	<ol style="list-style-type: none"> 1. Check the operating condition. 2. Check whether the heat dissipation channel is blocked. 3. Check the coolant level
	The motor is severely overtemperature	P100203	<ol style="list-style-type: none"> 1. Overhaul the motor or transmission system. 2. Check whether the heat dissipation channel is blocked. 3. Check the coolant level
	The MOS is generally overtemperature	P100402	<ol style="list-style-type: none"> 1. Check the operating condition. 2. Check whether the heat dissipation channel is blocked.
	The motor is generally overtemperature	P100502	<ol style="list-style-type: none"> 1. Check the operating condition. 2. Check whether the heat dissipation channel is blocked.
	Auxiliary power overvoltage	P100A13	Check the external input 12V power supply.
	Auxiliary power supply undervoltage	P100B13	Check the external input 12V power supply.
	busoff failure	P101443	<ol style="list-style-type: none"> 1. Check the cable and communication terminator; 2. Confirm the presence of interference
ECU	Short circuit of GPS antenna	P130321	<ol style="list-style-type: none"> 1. Check the GPS antenna wiring. 2. Replace the X-ECU and contact after-sale processing
	Open GPS antenna	P130421	<ol style="list-style-type: none"> 1. Check the GPS antenna wiring. 2. Replace the X-ECU and contact after-sale processing
	CAN_A BUSOFF	P130843	<ol style="list-style-type: none"> 1. Do not need to be processed if it is recoverable 2. Check whether the cable is in poor contact

Module	Fault		Solution
ECU	CAN_B BUSOFF	P130941	<ol style="list-style-type: none"> 1. Do not need to be processed if it is recoverable 2. Check whether the cable is in poor contact
	CAN_C BUSOFF	P130A43	<ol style="list-style-type: none"> 1. Do not need to be processed if it is recoverable 2. Check whether the cable is in poor contact
	Auxiliary power overvoltage	P130B11	<ol style="list-style-type: none"> 1. Check the external input 12V power supply
	Auxiliary power supply undervoltage	P130C11	<ol style="list-style-type: none"> 1. Check the external input 12V power supply
	The BMS node is missing	P130D41	<ol style="list-style-type: none"> 1. Check the BMS cables 2. Verify that the BMS are connected and powered properly
	The drive motor controller node is missing	P130E43	<ol style="list-style-type: none"> 1. Check the drive motor controller circuit and cable 2. Confirm whether the drive motor controller is connected and the power supply is normal
	The remote control node is missing	P131143	<ol style="list-style-type: none"> 1. Verify that the smart throttle is powered on 2. Check the wiring and cable of the smart throttle 3. Confirm whether the Smart throttle is connected and the power supply is normal
	Display panel node is missing	P131441	<ol style="list-style-type: none"> 1. Check the cable and cable of the display 2. Check whether the display is connected and the power supply is normal
	High voltage interlock 1 signal failure	P132002	<ol style="list-style-type: none"> 1. Recheck the high voltage interlock signal 1 cable 2. Replace the high voltage cable
High voltage interlock 2 signal failure	P132102	<ol style="list-style-type: none"> 1. Recheck the high voltage interlock signal 2 cable 2. Replace the high voltage cable 	

Module	Fault		Solution
Smart throttle	Abnormal throttle calibration data	H120203	<ol style="list-style-type: none"> 1. Recalibrate away from strong magnetic fields 2. If it occurs repeatedly, contact after-sales treatment
	Abnormal throttle Angle	H120003	Stay away from strong magnetic fields
	Abnormal safety switch	H120403	Check that the safety switch is properly sucked into the slot
Smart display	CAN BUSOFF	H110041	<ol style="list-style-type: none"> 1. Do not need to be processed if it is recoverable 2. Check whether the cable is in poor contact
	ECU LOST	H110141	<ol style="list-style-type: none"> 1. Do not need to be processed if it is recoverable 2. Check whether the cable is in poor contact

6 Maintenance

6.1 Repair and maintenance:

Maintenance cycle						
Components	Items	Work	First maintenance		Every interval thereafter	
			50 hours (or 3 months)	100 hours (or 6 months)	250 hours (or 1 year)	1000 hours (or 4 years)
Foot pads of suspension	Suspension repair and replacement	Check/Replace	●		●	
Gear box	Gear oil	Check/Replace		●		●
	Drain bolt	Check/Clean/Replace		●		●
	Oiling bolt	Check/Replace		●		●
Cooling system	Cooling water pump impeller	Check/Replace	●		●	
	Heat exchanger	Check/Replace	●		●	
Complete machine	Bolt and nut	Check	●		●	

6.2 Part of the repair and maintenance guide

6.2.1 Repair flexible impeller pump

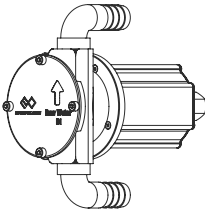

Water pump Assy

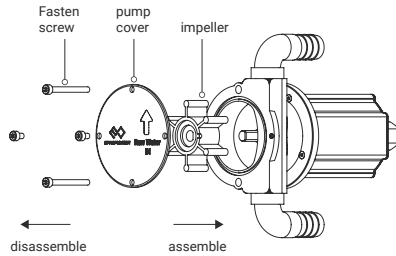

Figure

1. Use a 4mm hex wrench to remove the 4 fastening bolts on the pump cover of the impeller pump, and remove the pump cover;
2. Remove the old impeller. Use a rag to clean the residual grease, sand and other sundries inside the pump body and on the surface of the pump cover until no visible particles can be;
3. Check the O-ring and new impeller on the pump casing for damage (if any, it needs to be replaced);
4. Thin-coated grease on the pump casing cavity, impeller surface, inside of pump cover and O-ring surface (brand: INFIT 3#grease);
5. Align the impeller with the flat position of the motor shaft;
6. Install the impeller pump cover and tighten the fastening bolt;
7. Power on to check whether the pump is working normally.

6.2.2 Regular cleaning of heat exchanger

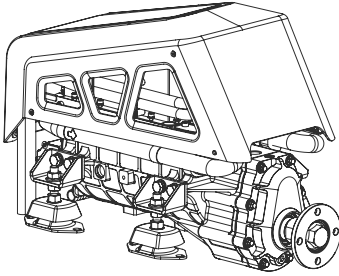

1

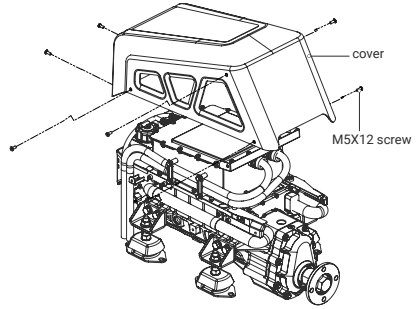

2

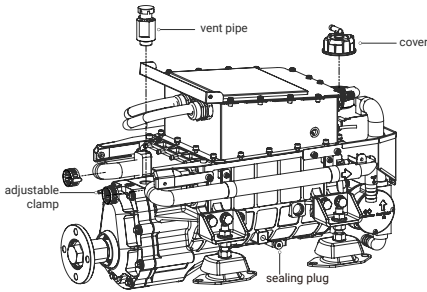

3

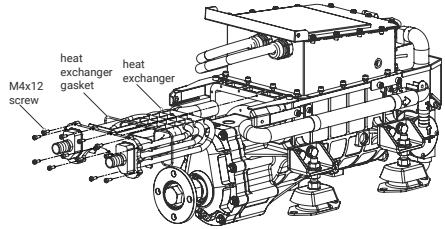

4

1. Remove 8 M5 × 12 inner hex flat head bolts (3 on both sides of the shell and 2 on the rear side) with a 3mm inner hex wrench and remove the I-20 shell;
2. Use the inner hexagon wrench with a specification of 5mm to remove the sealing plug. Due to pressure, the coolant will flow out slowly. Please pay attention to the placement of the container to prevent the coolant from leaking and polluting the environment.
3. Use the movable wrench to remove the I-20 vent pipe on the gearbox (be careful not to scratch the sealing ring of the I-20 vent pipe);
4. Use the outer hexagon sleeve to loosen the adjustable clamp on the outer circulating water pipe and remove the water pipe;
5. Use an inner hexagon wrench with a specification of 3 mm to remove 12 M4 × 12 inner hexagon cylindrical head bolts, take out the heat exchanger, and check whether the heat exchanger gasket is damaged (if so, the heat exchanger gasket needs to be replaced);

6. Soak the removed heat exchanger in marine life removal agent such as BarnacleBuster for 12 hours, and wash the outer surface and inner pipeline with water after soaking;
7. Install the cleaned heat exchanger to the assembly shell, and pay attention not to press the heat exchanger gasket during installation;
8. Install the external circulation water pipe to the pagoda head of the heat exchanger, and lock the adjustable clamp;
9. Tighten the I-20 vent pipe with a movable wrench, and pay attention not to press the sealing ring of the I-20 vent pipe during installation;
10. Inject 1.6L of ethylene glycol coolant (brand: Shell OTA -30 ° C) through the mouth of the water tank. When injecting the coolant, if the coolant of the water tank cannot be lowered, it is necessary to rotate the shaft flange and wait for the coolant of the water tank. After the liquid level drops, the coolant can be injected continuously until the rated amount of liquid is injected and the water tank cover is tightened;
11. Install the I-20 cover.

Note:

When the storage temperature is below -25 ° C, it is recommended to refer to the above steps to drain the coolant from the domestic circulation system of the machine.

6.3 List of fasteners

Assembly to be fastened	Items	Specifications	Locking reference moment (Nm)
Cover	Hex socket flat head screw	M5x12	1.5~2.0
Deflector series	Hex socket round head screw	M5x10	1.5~2.0
Fan fasteners	Hex socket round head screw	M5x10	1.5~2.0
Suspension foot fasteners	Hexagon bolt	M10x18	12~14.5
Suspension lock nut - up	Hex flange face nut	M12x1.75	21~23
Suspension lock nut - down	Hex nut	M12x1.75	21~23
Output shaft flange locking bolt	Hexagon bolt	M10x45	12~14.5
Output shaft flange locking nut	Hex nut	M10x1.5	12~14.5
Oil drain bolt	Hex bolt	M12x1.5	12~14
Oiling bolt	Hex seal plug	M10x1.0	8~10



Apply Loctite 243 to all screws of the machine when tightening them before leaving the factory. Apply thread glue to the screws when tightening them again for anti-loosening.

7 Warranty

Guangdong ePropulsion Technology Co., Ltd. (“ePropulsion”), China, warrants its products to be free of defects in material and workmanship under normal usage with proper installation and routine maintenance for a period of twenty-four (24) months from date of delivery of products to end customers (the “Limited Warranty Period”). The Limited Warranty is provided to the first end customer of ePropulsion products ONLY. The Customer is entitled to free repair or replacement of defective or non-conform parts. Any warranty claim must be made within six (6) months of discovery of issues as provided below.

If the Limited Warranty Period expires, you can still enjoy maintenance services from dealers/distributors authorized by ePropulsion (the “ePropulsion Service Partners”) with minimum maintenance charge per occurrence.

In all warranty cases, ePropulsion will only bear the repair cost and other costs (such as those related to product installation, disassemble, transportation, financing, rental, etc.) as a direct result for of issues covered by the Limited Warranty only. Any costs irrelevant to or out of the scope of the Limited Warranty will be born by the Customer alone., which shall NOT include costs irrelevant such as those related to product installation, disassemble, transportation, financing, rental, etc.

Beyond the Limited Warranty, the Customer may have statutory rights in your jurisdiction according to applicable laws. Nothing in this Limited Warranty affects such rights. The Customer may have warranty claim rights arising from the purchase contract with ePropulsion Service Partners in addition to the rights granted by this Limited Warranty.

Products for commercial/professional use, even if only temporarily, are not covered by the Limited Warranty. Instead, the statutory warranty in your jurisdiction shall apply. You are encouraged to consult with ePropulsion Service Partners for applicable warranty and advice before engaging in such use.

*** Commercial/professional Use refers to application cases that have high use frequency, high-reliability requirement or aim for money making, etc.**

To keep your warranty valid, you shall follow:



Keep the product label intact and record the Serial Number shown on the label. Never tear the label off the product. A product without the original product label is not covered by the Limited Warranty provided by ePropulsion;



The Limited Warranty is not transferable and will not be reissued;



The Limited Warranty may change from time to time. Pls visit our website (<http://www.epropulsion.com>) for the latest version.

7.1 Out of Warranty

ePropulsion may refuse a warranty claim if:

- Any improper operation contradicts what is written in the user manual;
- Accident, misuse, dropping, improper care or storage, willful abuse, physical damage, overcharging, over discharging, or unauthorized repair;
- Water ingress caused by external sources such as fishing nets, submerging underwater, etc;
- Product modification, alternation, disassembly, or parts/accessories attachment, which are not expressly permitted or recommended by ePropulsion;
- Failure of, or damage caused by, any 3rd party products;
- Consumables are out of warranty scope (like propeller, anode...etc.);
- Purchases of product from unauthorized dealers or seller;
- Normal wear and tear and routine servicing are excluded from the warranty;
- The product gets further damaged due to improper packing during delivery. The further damaged part will be deemed as out of warranty coverage;
- Lithium battery is classified as a UN9 hazardous item, posting and packing must be in accordance with the relevant law of the local country directive. Non-compliance may result in out of warranty coverage.

7.2 Limited Warranty Claim Procedures

The Customer shall follow the warranty claim process to make a Limited Warranty claim:

1. Contact your nearest ePropulsion Service Partners and they will provide further instruction to you if such defects are covered by the Limited Warranty or theirs.
2. Send the defective product to them together with Proof of 1(st)-time Purchase (e.g., receipt, invoice, etc., with information of product purchased and date of purchase), the Confirmation of Online Warranty Registration, ex-factory Serial Number, etc. Note that all labels shall be kept intact. The warranty is valid only when the information above is correct, genuine, and complete;
3. Make sure the product is properly packed during delivery, the original package is highly recommended.
4. The ePropulsion Service Partners will conduct diagnosis and examination on the defective products to check the validity of the warranty claim.
5. If your warranty claim is accepted, the Product or its defective components/parts will be either repaired or replaced free of charge. Note that any delivery cost incurred in the process shall be bearded by you.
6. In case your warranty claim be rejected, a repair/replace cost and fee with round trip delivery cost will be estimated and sent to you for confirmation. ePropulsion Service Partners will only begin the work after your written confirmation.

WARRANTY CARD || ePropulsion Control System

(*In order to validate warranty, please fill in this form first and read the Warranty Policies.)

|| OWNER INFO. ||

Owner Name			
Address			
Phone		Email	

|| DEALER INFO. ||

Store Name			
Address			
Phone		Email	

|| PRODUCT INFO. ||

Date of Purchase (mm/dd/yyyy)	
Serial No.	



Scan to register
your product



Product
tutorial

Thanks for reading this user manual.

If you have any concerns or find any problems while reading,
please don't hesitate to contact us. We are delighted to offer
service for you.

Guangdong ePropulsion Technology Limited

Webseite: www.epropulsion.com

E-Mail: service@epropulsion.com